

Main Features of this Decoder

Back EMF Load Compensation for superior slow speed control even with heavy loads.

- **Quiet Drive** creates SUPER QUIET engine performance.
- **Autodetect** for realistic throttle response when using DC power.
- **Dimmed Brightness** of bulbs or LEDs is adjustable.
- **Variable Momentum** lets you make custom acceleration curves.
- **Ditch Lights:** control alternating ditch lights with realistic pulsing.
- **Mars, Gyra, and Rotary Beacon** are adjustable.
- **Decoder Lock** for programming same address decoders independently.
- **Function Remapping:** 13 buttons for most lights, 7 buttons for operations.

Other Features of This Decoder: This decoder has too many features that could be listed on this page. For the complete list of available features, print out the "Additional Programming Guide" that can be found in the literature section of our website (www.tcsdcc.com). Some of the features include: Function Remapping, 3 Point Acceleration/Deceleration Curves, Button Control of the Motor, Loadable Speed Tables, Various lighting effects, decoder lock and many more.

WARRANTY PROCEDURE: All decoders are covered by a one year goof proof, no questions asked warranty. Please return in a padded envelope or small box. NOTE: A4X, A6X, DP2X, and all drop in N-scale decoders must be returned in a small box.

1. You must register the failed decoder on our website at www.tcsdcc.com.
2. Print out a copy of the Warranty Registration and include it in the padded envelope or box with the decoder(s).
3. Return decoder(s) directly to us using the address below.

Compatible with NMRA DCC standards.

Made by TCS in the USA.

Train Control Systems
P.O. Box 341
845 Blooming Glen Rd.
Blooming Glen, PA 18911



Phone **215-453-9145**
Fax **215-257-0735**
Email tcs@tcsdcc.com
Web www.tcsdcc.com



Our Famous GOOF PROOF NO
Questions Asked Warranty

1333 **KOD8-B**

| Scale | Functions | Function Rating | Continuous/Peak |
|-------|-----------|-----------------|-----------------|
| N | 8 | 80 mA | 1.0 /2.0 Amp |

Dimensions: 2.138"x0.542"x0.068" or 54.32mm x 13.766mm x 1.73mm

This full featured BEMF decoder is designed to fit the Kato N-Scale F3A and F7A locomotives. Included is our auto-adjusting BEMF for outstanding slow speed performance and hassle free set up. Also includes Quiet Drive for super quiet engine performance.

WIRING DIAGRAM

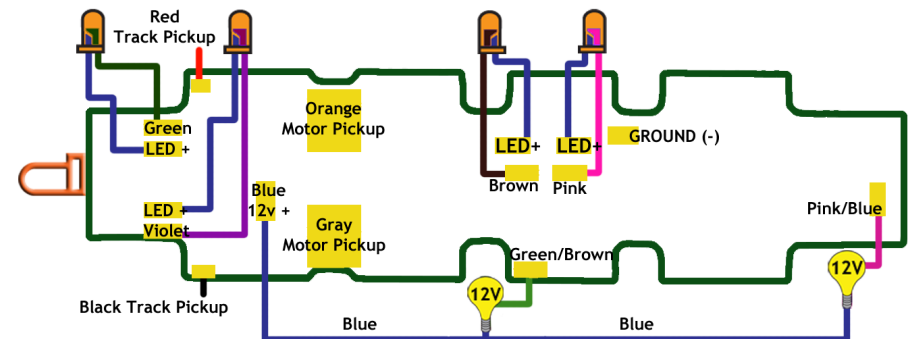

INSTALLATION

For detailed installation pictures visit our website where we maintain a constantly growing database of a wide range of locomotives and decoders.



1333 **KOD8-B**

WORKSHEET INSTRUCTIONS

- A blank outlined box is provided by each CV number. This is so you can preplan your decoder and have a record of your choices.
- In many cases you are recording a single value such as an address, a rate, or a limit.
- In some cases you are choosing more than one value such as actions, functions, or buttons. Each of these will have a value. Add the values of those you want active and enter that sum in the blank box.
- The other box by the CV number is the factory set value. If it is shaded, it can be reset with Factory Reset.

BASIC CONFIGURATION

Circle the values by all of the changes you want to make.

| | | | | |
|-------|---|---|----|--|
| 1 | A | 0 | 1 | Reverse the direction the engine runs. |
| | B | 2 | 2 | Use 28/128 speed step mode. |
| | C | 4 | 4 | Enable analog (DC) operation. |
| | D | 0 | 16 | Make the Loadable Speed Tables active. |
| | E | 0 | 32 | Make the decoder address 128 or higher. |
| CV 29 | 6 | | | Adjust the Default Value by the values you have circled. |

ADDRESSING

2 Digit Address Use if the address is 127 or less.

| | | | | |
|---|------|---|--|--------------------------|
| 2 | CV 1 | 3 | | Record your choice here. |
|---|------|---|--|--------------------------|

4 Digit Address Make sure Table 1 "E" = 32.

| | | | | |
|-------|---|--|--|---------------------------------------|
| 3 | Your command station will assign the values of CV 17 and CV18 | | | |
| CV 17 | 0 | | | ← Record your four digit address here |
| CV 18 | 0 | | | |

For more information about CV 17 and 18 visit our web entry on this topic at:
http://www.tcsdcc.com/faq/four_digit_addressing.htm

Consist Address If this is greater than 0, the regular address is unalterable.

| | | | | |
|-------|---|--|--|---|
| 4 | Add 128 to reverse the loco when in consist. Some systems only! | | | |
| CV 19 | 0 | | | Use a 2 digit address when in a consist (Multiple units). |

Decoder Lock Same address decoders need a different sub address in CV 16.

| | | | | |
|---|--|---|------------------|---------------------------|
| 5 | To unlock a decoder, make CV 15 = 0 or CV 15 = CV 16. To lock a decoder, make CV 15 not equal to CV 16. To lock all same address decoders, make CV 15 = 7. | | | |
| | CV 15 | 0 | All unlocked = 0 | Decoder to unlock = 1 - 6 |
| | CV 16 | 1 | Mobil = 1 | Sound = 2 |
| | | | Light Only = 3 | ___ = 4 |
| | | | ___ = 5 | ___ = 6 |

MOTOR CONTROL

Speed Graph 1 volt = 18 0 produces straight line acceleration.

| | | | | |
|---|------|---|-------------|---|
| 6 | CV 2 | 0 | Start Volts | Set the voltage when the throttle is first applied. |
| | CV 6 | 0 | Mid Volts | Set the voltage when the throttle is at midpoint. |
| | CV 5 | 0 | Top Volts | Set the voltage when the throttle is at full speed. |

□□□□□□□□

Momentum

The effect of engines starting and stopping heavy loads.

| | | | | |
|---|-------|---|--|--|
| 7 | CV 3 | 1 | Acceleration | Larger values add time to each speed step. |
| | CV 4 | 1 | Deceleration | Larger values add time to each speed step. |
| | CV 23 | 0 | *Acceleration Adjustment when in Consist | |
| | CV 24 | 0 | *Deceleration Adjustment when in Consist | |

*Values above 128 increase the adjustment * Values below 128 decrease the adjustment

Dither If BEMF is turned off dither can provide an alternate form of speed control.

| | | | | |
|----|-------|----|------------------|----------------------------|
| 10 | CV 56 | 3 | Dither Frequency | The highest frequency = 1. |
| | CV 57 | 10 | Dither Voltage | The lowest voltage = 1. |

NOTE: Both CV 56 and CV 57 must be greater than 0 for Dither to be active.

Back EMF, Rule 17 Dimming Options and Opposite Dim Control

Even number OR 0= BEMF OFF Odd number = BEMF ON

| | | | | | | | | |
|----|---|----|---|--|-------------------------|----------------------------------|-------------------------------|--|
| 13 | BEMF disabled = 0 | | BEMF enabled = 1 | | BEMF button control = 3 | | Dims when stopped = 16 | |
| | To turn on BEMF and function button control of it, put 3 into CV 61 | | | | | | Opposite light is dimmed = 32 | |
| | CV 61 | 1 | BEMF and Dimming Control | | | BEMF+Stopped + Opposite dim = 49 | | |
| | CV 136 | 2 | Function button control of BEMF | | | Bits 0-7 designates buttons 5-12 | | |
| | CV 64 | 15 | Dimmed Brightness (2 – 6 for LEDs, 12 – 18 for Bulbs) | | | | | |
| | CV 10 | 0 | BEMF Cut Out <small>For more information go to www.tcsdcc.com/BEMF.pdf</small> | | | | | |

LIGHTING CONTROL

| Light Function Wires | | | | Light Effect | | | | |
|----------------------|-------|-------|-------------|--------------|-------------------------------|-----|-----|------|
| | CV | Value | Wire | Function | Light Effect | fwd | rev | both |
| 11 | CV 49 | 0 | White Wire | F0F | Constant Bright Light | 0 | 16 | 32 |
| | CV 50 | 16 | Yellow Wire | F0R | Random Flicker (fire box) | 1 | 17 | 33 |
| | CV 51 | 32 | Green Wire | F1 | Mars Light | 2 | 18 | 34 |
| | CV 52 | 32 | Purple Wire | F2 | Flashing Light | 3 | 19 | 35 |
| | CV 53 | 32 | Brown Wire | F3 | Single Pulse Strobe | 4 | 20 | 36 |
| | CV 54 | 32 | Pink Wire | F4 | Double Pulse Strobe | 5 | 21 | 37 |
| | CV 55 | 32 | Pink/Purple | F5 | Rotary Beacon | 6 | 22 | 38 |
| | CV 58 | 32 | Green/Brown | F6 | Gyra Light | 7 | 23 | 39 |
| | | | | | Rule 17 (dimmable light) | 8 | 24 | 40 |
| | | | | | Ditch Light (Left or Right) | 10 | 26 | 42 |
| | | | | | Ditch Light (Other side) | 11 | 27 | 43 |
| | | | | | Constant Dim light (50%) | 12 | 28 | 44 |
| | | | | | *Auto-Mars | 13 | 29 | 45 |
| | | | | | Brake Lights | 14 | 30 | 46 |

* Auto-Mars: Automatically turns Mars light on when decelerating below 36% speed. This setting also turns the Mars light on steady above 36% speed. Rule 17 must be enabled in table 11 to enable dimming options in table 13.

Rule 17 Dimming Control

Rule 17 Dimming is turned on and off by button 4 as the default, but this value can be remapped via CV 123. See the Function Remapping guide on the literature section of www.tcsdcc.com for more info.

Analogue (DC) Power Control Turn off Black or Red wire powered functions.

| | | | |
|----|-------------|-----|--|
| 17 | CV 13 | 255 | Activate power to light functions on DC |
| | Brake on DC | | Activate by subtracting 4 from CV 29 in table 1. |

Consist Lighting Control

| | | | | |
|----|-------|---|---------------------|------------------------------------|
| 18 | CV 21 | 0 | Extra Functions | Green, Purple, Pink and Brown = 15 |
| | CV 22 | 0 | Headlight Functions | White and Yellow Wire = 3 |

Factory Reset

Sets all CVs with a shaded value back to that value.

| | | | |
|----|------|-----|------------------------------------|
| 20 | CV 8 | 153 | Enter 2 to perform a Factory Reset |
|----|------|-----|------------------------------------|