

Getting started

Thank you for purchasing a *Logic Rail Technologies* product! Please read all instructions prior to installing this board. You're probably wondering why such a relatively simple product like this needs FOUR pages of instructions! We have two reasons. First, the Signal Animator is extremely versatile and can be used with a wide variety of signals. Second, we'd rather provide you with too much information rather than not enough!

The Signal Animator provides automatic operation of 3-color block signals in a semi-prototypical way. A photocell is used for train detection. Anytime the photocell is covered by any portion of a train the signal will turn red. Once the photocell is uncovered the Signal Animator will delay (10 or 30 seconds; see below) and then change the signal to yellow. After another delay the signal will be changed to green.

This version of the Signal Animator (model SA-1) provides 3-color signaling for LED-based 3-light (common anode) and searchlight-style signals.

You should make all of the connections to the Signal Animator before applying power to it. You can mount the Signal Animator anywhere it is convenient underneath your layout using the four mounting holes provided. The holes will accept #4 screws; do not enlarge the holes as damage to the circuit board can result and your warranty will be voided!

Searchlight Signals (Sunrise Enterprises, Tomar Industries, Oregon Rail Supply, etc)

To select a searchlight signal on the Signal Animator you must have the "jumper" installed over both pins on the "block" labeled "SIG" on the circuit board. This is illustrated in Figure 1. The LED used in model searchlight signals is commonly called a bipolar or tri-color LED. This type of LED has two elements inside of a single housing; one element is green and the other is red. There are two ways that these LEDs are internally wired. One has two leads and the other has three leads; the three-leaded variety is the most common. The Signal Animator supports either one as shown in Figures 2a & 2b. You **MUST** use resistors with LED-based signals! Because the Signal Animator provides +5V power to the LED we recommend a resistor value of 150 ohms. We have included three resistors with this product.



Figure 1 – selecting searchlight signals

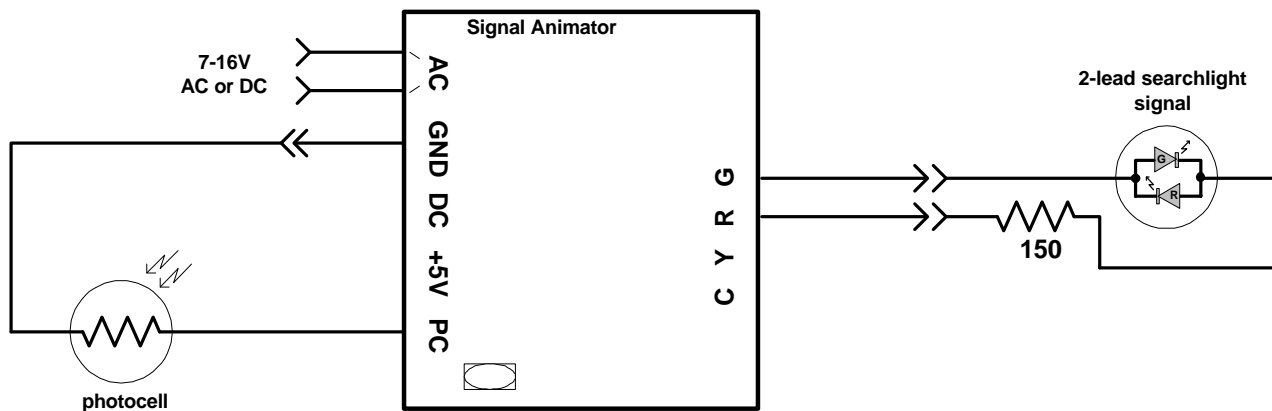

Figure 2a – 2-lead searchlight signal

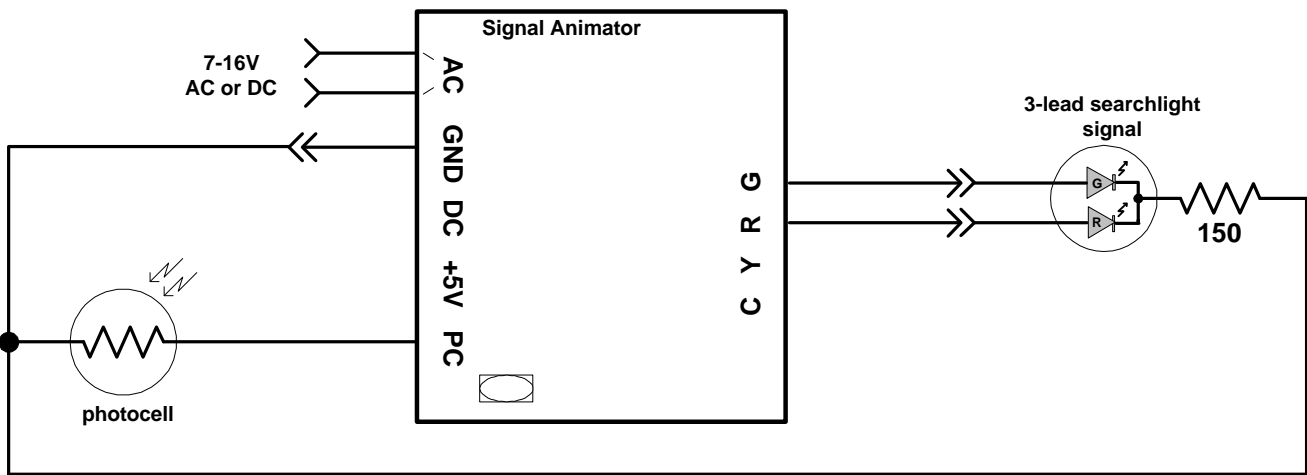

Figure 2b – 3-lead searchlight signal

You can adjust the yellow hue on an LED searchlight signal using the jumper on the block labeled "HUE" on the circuit board. If the jumper covers the top two pins then the yellow hue will be more reddish and less green; if the jumper covers the bottom two pins then the yellow hue will be more greenish and less red. You must choose one or the other! This is illustrated in Figure 3.



Figure 3 – adjusting yellow hue

3-light LED Signals (Tomar Industries, Oregon Rail Supply, Jay’s, etc)

To select 3-light signals you must have a jumper covering only the center pin on the "HUE" block on the circuit board. This is illustrated in Figure 4. In addition, a jumper must only cover one pin (it doesn't matter which one) on the "block" labeled "SIG" also shown in Figure 4. The Signal Animator directly controls 3-light LED signals wired in a common-anode (the anode is the positive side of the LED) arrangement. Virtually all brands of 3-light signals are wired this way. One known exception are those from Integrated Signal Systems which are wired in a common-cathode arrangement. We offer the Signal Animator Deluxe model SAD-CC for controlling this type of signal.

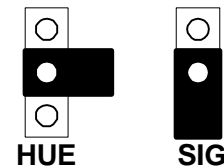

Figure 4 –selecting 3-light signals

You MUST use resistors with LED-based signals! Because the Signal Animator provides +5V power to the LED we recommend a resistor value of 150 ohms. We have included three resistors with this product. Since only one LED will be illuminated at a time you can choose to use a single resistor in the common anode path or individual resistors in each of the LED cathode paths. The individual resistor scheme is illustrated in Figure 5.

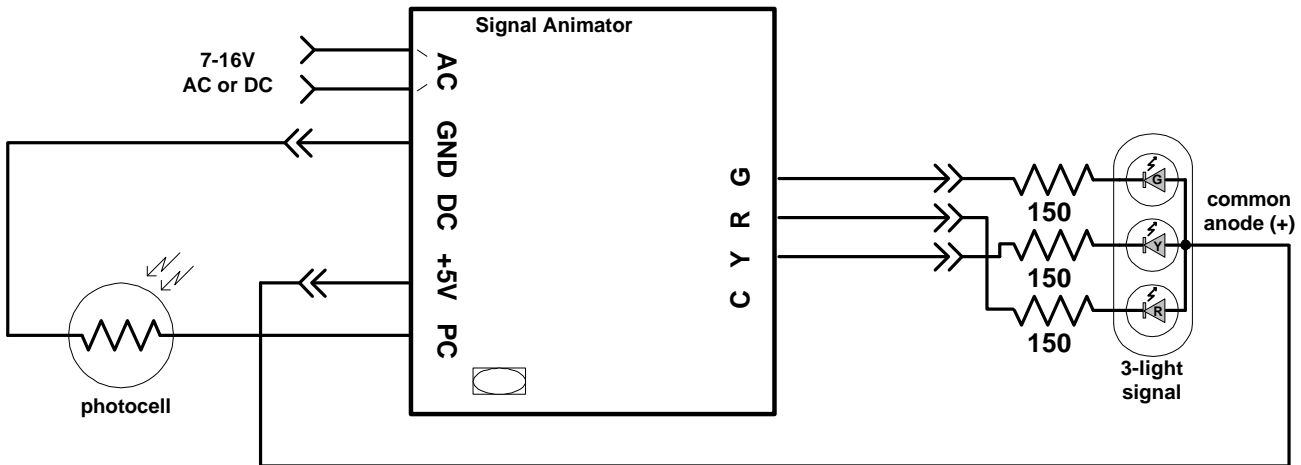

Figure 5 – 3-light signal

The Photocell

The photocell should be mounted between the rails in the general area where you will locate the signal. Drill a 9/64" hole through the ballast, roadbed, and sub-roadbed. For the smaller scales this drilling may end up hitting the ties. Take your time so you don't mangle them! Figure 6 illustrates the placement of the photocell in between the rails. Insert the leads of the photocell into the hole from the top of your layout. One of the photocell leads has a piece of insulation on it so be sure the two leads don't touch each other (you won't damage anything if they do but the circuit won't work

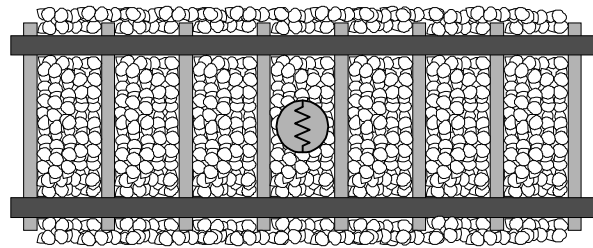

Figure 6 – photocell placement

properly!). If the leads do not protrude enough from the underside of your layout then it will be necessary to extend the leads; soldering wires to them is the most common method; make sure you insulate any connections you make to the photocell leads so that they don't short out. Once you have wired the photocell to the Signal Animator and verified its operation you may wish to put a dab of white glue under the photocell to hold it in place; make sure you don't get glue on the top surface of the photocell as this may prevent it from operating properly.

The photocell requires a light source above it to function properly. On most layouts the room lighting should be sufficient. However, if the photocell is located in an area that doesn't get much overhead lighting or if you have simulated "nighttime" operations then it will be necessary to locate a light source on the layout near the photocell. Street lights and yard lights are common light sources. Locate the light source slightly to the left or right of the photocell and not directly over it; this will allow the Signal Animator to still properly detect a train that has stopped over the photocell with the gap between cars over the photocell. You can adjust the sensitivity of the photocell on the circuit board using a small slotted head screwdriver. Insert the screwdriver in the component labeled "VR1". Turning the screwdriver clockwise will compensate for lower light levels. With nothing blocking the photocell turn the screwdriver counter-clockwise until the signal changes to red. Then slightly turn the screwdriver clockwise. Repeat if necessary.

Signal delay

The signal color change delay can be either 10 seconds or 30 seconds. Choose the value based on your own personal preference. To select 10 seconds the jumper must be installed over both pins on the block "DLY"; for 30 seconds the jumper must only cover one pin (it doesn't matter which one). You can change this as you wish even when the power to the Signal Animator is on. The two options are illustrated in Figure 7.

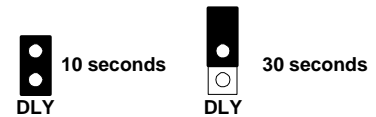

Figure 7 – signal delay

Power

The Signal Animator accepts AC or DC power (7 - 16V). Power consumption for LED signals is approximately 25mA (including the signal itself). If you are only using a single Signal Animator then use the AC terminals to provide power as previously shown. You can use the accessory terminals on your throttle/power pack. If you are using more than one Signal Animator you can power them all from a single **DC** source as shown in Figure 8 below.

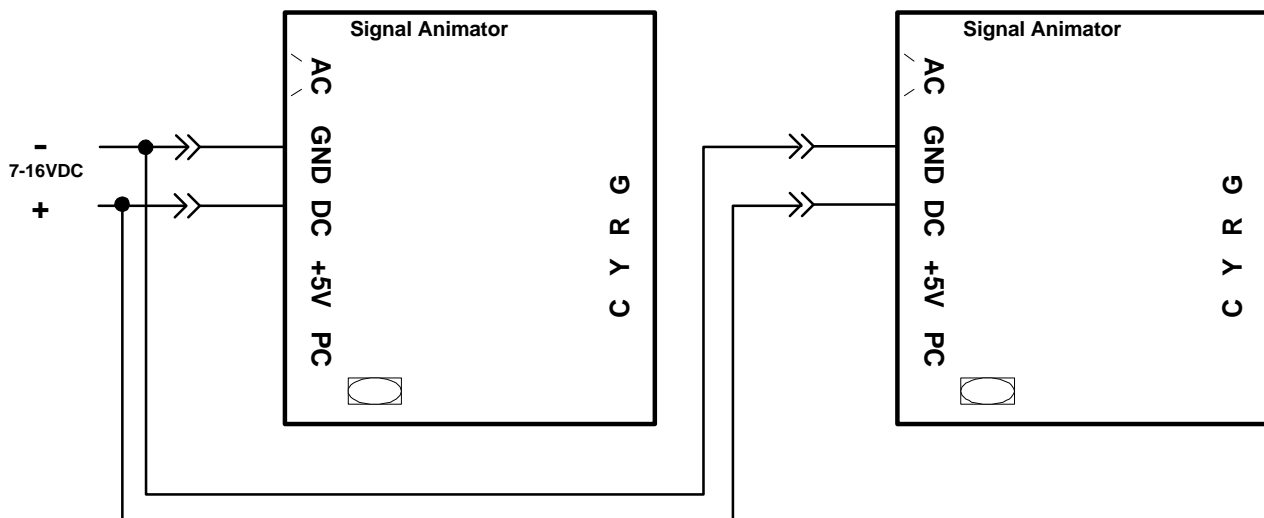

Figure 8 – DC power

Multiple signals

It is possible to use two signal heads with one *Signal Animator*. This arrangement could be used to mimic a standard block signal arrangement. The signal heads will be wired in parallel with each other (we recommend that each signal has its own resistor(s) and that the value of the resistor(s) be increased to 220 ohms) and obviously will always show the same indication. This is shown in Figure 9 below; this diagram uses 3-lead searchlight signals as an example.

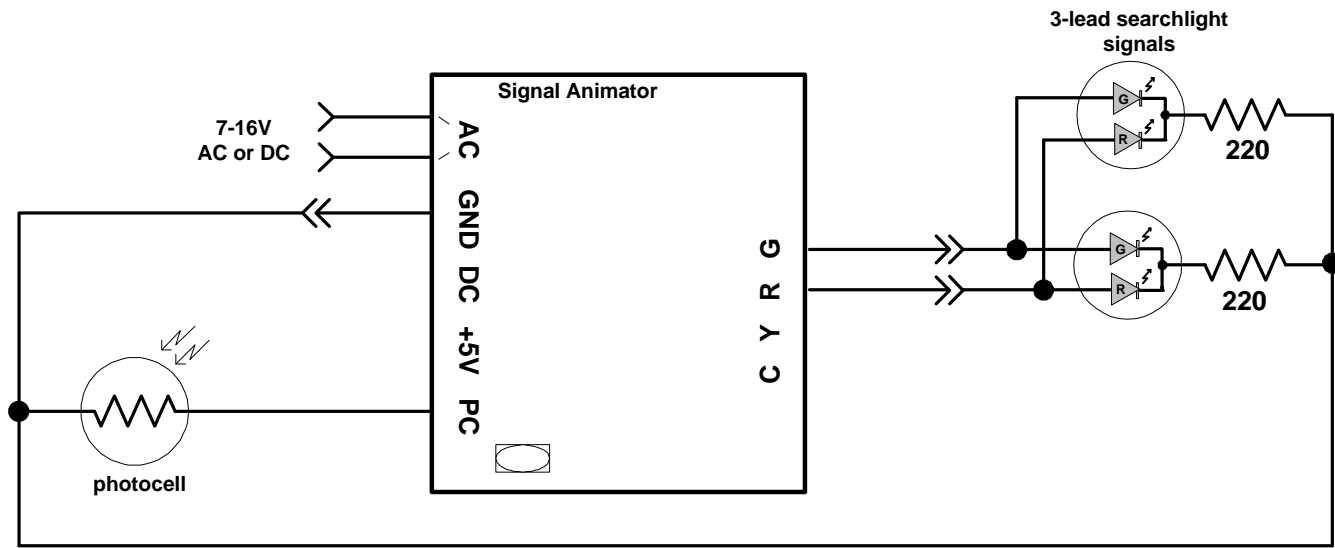

Figure 9 – Multiple signals (3-lead searchlight signal example)

Multiple photocells

An additional photocell (available from us at a cost of \$2.00) can be used in order to increase the zone of detection. Wire the two photocells in series (i.e. connect one lead from photocell #1 to the GND terminal, connect the other lead from photocell #1 to one lead of photocell #2, connect the remaining lead of photocell #2 to the PC terminal).

Other Applications

Please contact us if you are interested in knowing how to interlock your signal (i.e. force it to red) with the position of a turnout or if you are interested in controlling a dual head signal with two *Signal Animators*. You can also access this documentation online from our website at http://www.logicrailtech.com/lrt_docs.htm

Warranty

This product is warranted to be free from defects in materials or workmanship for a period of one year from the date of purchase. *Logic Rail Technologies* reserves the right to repair or replace a defective product. The product must be returned to *Logic Rail Technologies* in satisfactory condition. This warranty covers all defects incurred during normal use of this product. This warranty is void under the following conditions:

- 1) If damage to the product results from mishandling or abuse.
- 2) If the product has been altered in any way (e.g. soldering).
- 3) If the current or voltage limitations of the product have been exceeded.

Requests for warranty service must include a dated proof of purchase, a written description of the problem, and return shipping and handling (\$5.00 inside U.S./\$8.00 outside U.S. - U.S. funds only). Except as written above, no other warranty or guarantee, either expressed or implied by any other person, firm or corporation, applies to this product.

Troubleshooting

If your signal is not changing colors when the photocell is covered or stays red all the time you can perform the following tests. First, disconnect the photocell. With no photocell connected the *Signal Animator* will turn on the red output and keep it on. If the signal stays green then you either have the signal wired backwards (reverse R and G connections) or the *Signal Animator* or photocell is faulty. You can also temporarily connect the GND terminal to the PC terminal. The *Signal Animator* will turn on the green output and keep it on. If the signal stays red (allow for the delay period to expire) then you either have the signal wired backwards (reverse R and G connections) or the *Signal Animator* or photocell is faulty.

Technical Support

We hope the preceding instructions are sufficient for answering any questions you might have about the installation of this product. However, technical support is available should you need it. We would ask that you first contact your place of purchase for assistance. If you still need further assistance then please do not hesitate to contact us. You can reach us via phone, fax, mail and email; our contact information can be found on the top of page 1.