

Getting started

Thank you for purchasing a *Logic Rail Technologies* product! Please familiarize yourself with all the instructions prior to installing this board.

The *Grade Crossing Pro* (GCP) provides prototypical operation of a grade crossing. Four photocells are used for bidirectional train detection. The layout of the signals and photocells is illustrated below.

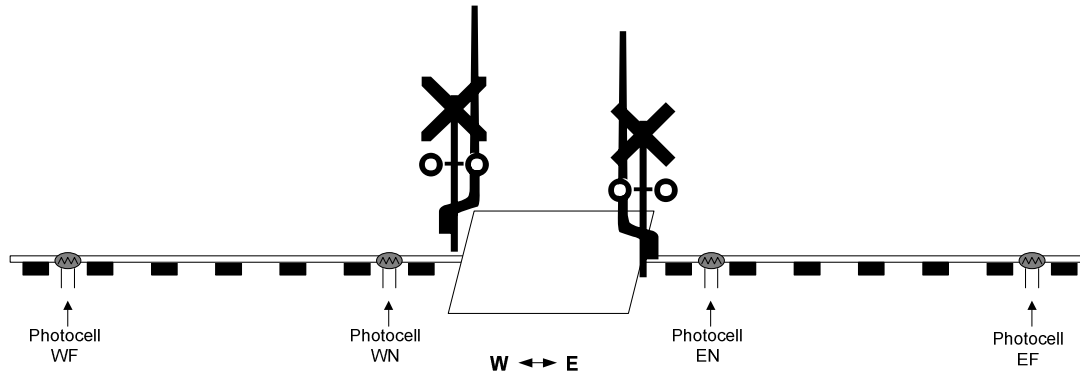

The GCP operates as described next. An eastbound (left to right) train will cause the signals to begin flashing when WF is covered. Approximately 2 seconds later the gate motor output will turn on and the gates will move down (if present). The signals will continue to flash even if it uncovers photocell WF as long as the train reaches photocell WN within 35 seconds. Assuming the train does this and then subsequently covers photocell EN the signals will continue flashing. Approximately 2 seconds after the last card of the train uncovers photocell EN the gate motor output will shut off and approximately 3 seconds later the signals will stop flashing. If the train had not covered photocell WN within 35 seconds of uncovering photocell WF then the GCP will assume the train has reversed. This “timeout” will cause the gate motor output to shut off and the signals will stop flashing (~3 seconds after gate motor shut off). Similar behavior exists for a westbound train with respect to photocells EF, EN and WN (shut off occurs after the last car uncovers photocell WN).

You should make all of the connections to the GCP before applying power to it. You can mount the GCP anywhere it is convenient underneath your layout using the four mounting holes provided. The holes will accept #4 screws; do not enlarge the holes as damage to the circuit board can result and your warranty will be voided!

The GCP board has 2 configuration switches on it. Each switch is described below.

Switch Name	Meaning when OFF/OPEN	Meaning when ON/CLOSED
SETUP	GCP is in normal operating mode	GCP is in sensor setup mode
LP	No Lamp Persistence (TrueLamp2)	Lamp Persistence (TrueLamp2) enabled

The SETUP switch is used to set your sensors’ sensitivity. Refer to page 4 for the sensor setup procedure. The LP (Lamp Persistence) switch, also known as TrueLamp2, feature provides realistic fading in and out of signals while flashing. This feature can be used with either LED-based or bulb-based signals. Note that due to the technical nature of how this is accomplished, it may potentially shorten the life of bulb-based signals; there are no concerns with LED-based signals!

The next two pages provide the wiring details for the crossing signals and gates (if applicable). The crossing signals fall into 3 categories:

- Tomar’s LED-based signals
- Other brands (including scratch-built) of LED-based signals such as Walthers
- Bulb-based signals

Refer to the appropriate section for the type of signal you are connecting to the GCP.

Wiring Tomar's LED-based crossing signals

Tomar's LED-based crossing signals are pre-wired in a common anode (positive) manner. Since these are dual-sided signals (i.e. LEDs on both sides of each signal mast) there are 2 yellow and 2 red wires (one from each LED's cathode) and one common white wire. Figure 1 below shows you how to wire ONE signal. The GCP will support two dual-sided signals; if you are using two signals then simply replicate the wiring shown for the second signal. Note that EACH LED connection requires a current limiting resistor. The value of the resistor is dependent upon the voltage applied to the GCP. You can use Table 1 to determine the resistor value. Note that some of the resistors can be ¼ watt whereas others must be ½ watt. You can always substitute a ½ watt resistor for a ¼ watt resistor but you CANNOT substitute a ¼ watt resistor for a ½ watt resistor!

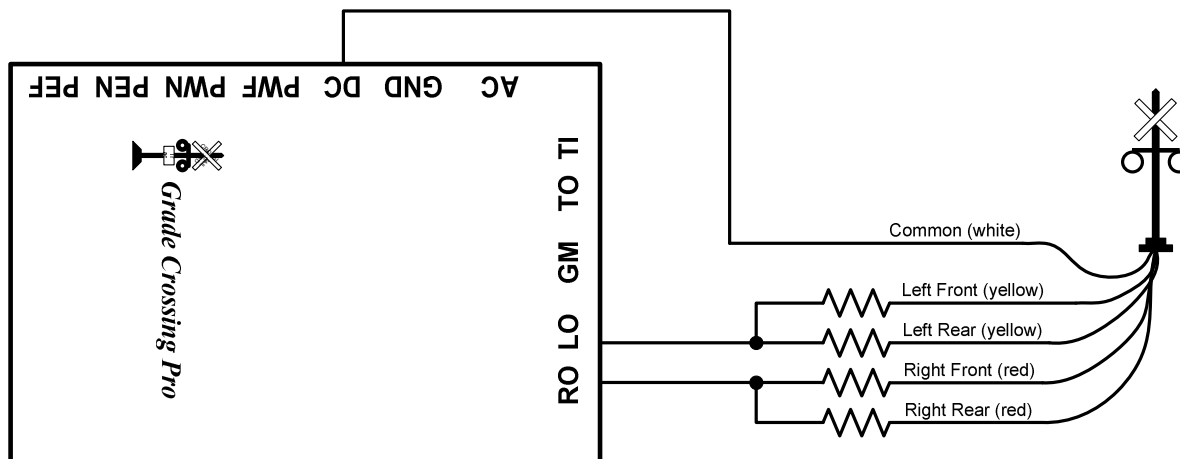

Figure 1 – Wiring Tomar's LED-based signals

Input Voltage	Resistor Value
9V DC	390 ohm, 1/4W
12V DC	470 ohm, 1/4W
16V DC	680 ohm, 1/2W
9V AC	560 ohm, 1/4W
12V AC	750 ohm, 1/2W
16V AC	1K ohm, 1/2W

Table 1 – Current limiting resistors

Wiring other LED-based crossing signals (including Walthers)

If you are using another brand of LED-based crossing signals, or are scratch-building your own, you MUST wire them in a common anode (positive) manner. Figure 2 below shows you how to wire ONE single-sided signal; if you are using multiple signals, or dual-sided signals, simply duplicate the wiring shown for the additional LEDs. Each of the GCP's signal outputs can handle loads up 180mA (~12 LEDs). Note that EACH LED connection requires a current limiting resistor. The value of the resistor is dependent upon the voltage applied to the GCP. You can use Table 1 above to determine the resistor value. Note that some of the resistors can be ¼ watt whereas others must be ½ watt. You can always substitute a ½ watt resistor for a ¼ watt resistor but you CANNOT substitute a ¼ watt resistor for a ½ watt resistor!

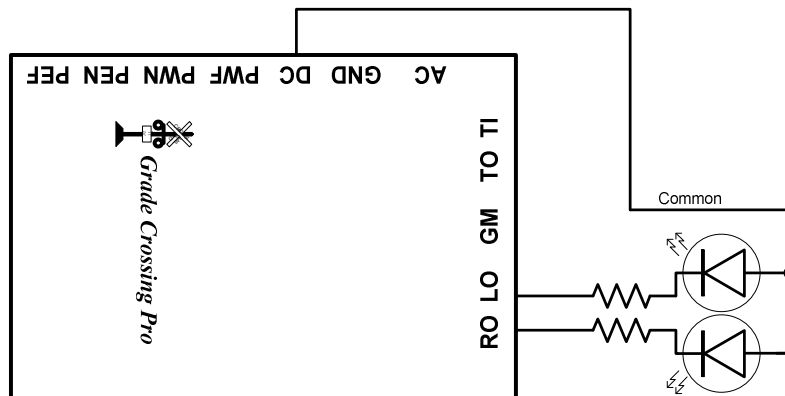

Figure 2 – Wiring LED-based crossing signals

Wiring bulb-based crossing signals (e.g. NJ International)

Crossing signals constructed with bulbs do not have a polarity like LED-based signals do. However, some bulb-based signals may be pre-wired with a common wire. If your signal does not, then you will simply create a common connection from one lead of each bulb (it doesn't matter which lead is used). Figure 3 below shows you how to wire ONE single-sided bulb-based signal. The GCP will support two dual-sided signals; if you are using multiple signals, or dual-sided signals, then simply

replicate the wiring shown for the additional bulbs. Note that current limiting resistors are shown. These are only required IF the voltage provided to the GCP is greater than the rating on the bulbs; most bulbs are rated at 12V AC or DC but you should check the instructions that come with the signal. If the GCP voltage source exceeds the bulb rating then add current limiting resistors as shown below; we recommend a value of 100Ω, ¼ watt.

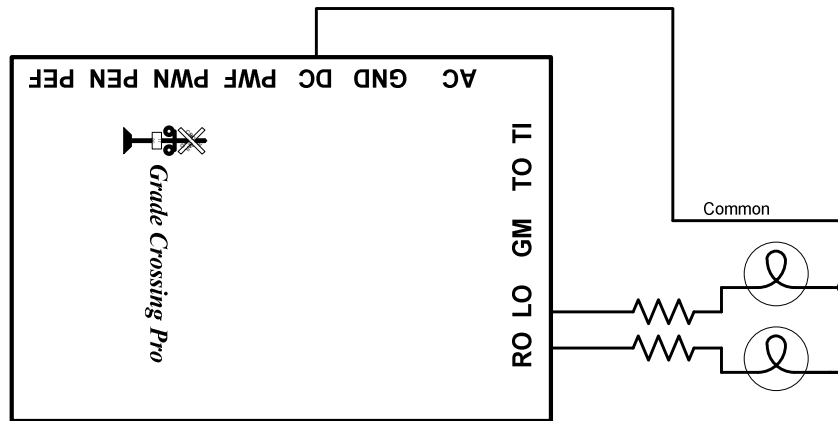

Figure 3 – Wiring bulb-based crossing signals

Wiring crossing gates

The GCP will directly drive a slow motion motor that is typically used with crossing gates such as those from Tomar. Figure 4 shows how the GCP is connected to a motor; the GCP can drive a max of two motors (one per gate if you prefer to use separate motors). If the gates are raised when the signals are flashing and lower when the signals are not flashing then you simply need to reverse the motor connections. You can adjust the speed of the gate motor on the GCP. Using a flat blade screwdriver insert it into the gate speed adjustment pot (from the edge of the circuit board, not from the center of the board). Turning the screwdriver clockwise will increase the gate speed while turning the screwdriver counter-clockwise will decrease the gate speed. **NOTE: You must check the instructions for your gate motor to determine the maximum voltage that the motor can accept. For example, Tomar uses Circuitron’s Tortoise™ which has a maximum voltage rating of 12V DC or AC. If the voltage provided to the GCP is greater than the rating on the motor then you will need to add a current limiting resistor (we recommend a value of 390Ω, ½ watt) in the connection path between one of the GCP’s GM outputs and the turnout motor. You may also wish to consider using our 12VPSR which converts AC (>12V) or DC (>14V) into a regulated (fixed) 12V DC output.**

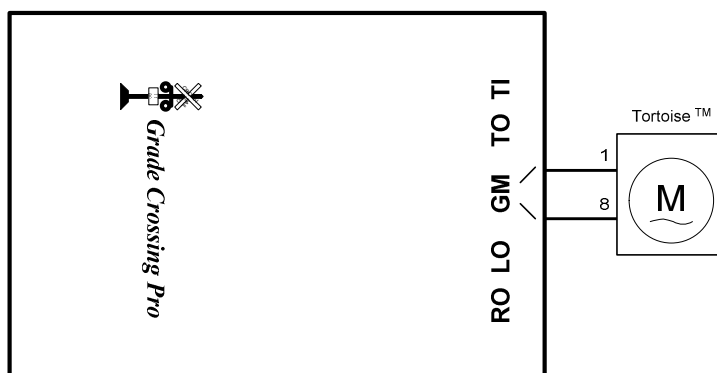

Figure 4 – Gate Motor Wiring (Tomar example)

The Photocells

The photocells should be mounted between the rails. Drill a 9/64" hole through the ballast, roadbed, and sub-roadbed. For the smaller scales this drilling may end up hitting the ties. Take your time so you don’t mangle them! Figure 5 illustrates the placement of a photocell in between the rails. Insert the leads of the photocell into the hole from the top of your layout. One of the photocell leads has a piece of insulation on it so be sure the two leads don’t touch each other (you won’t damage anything if they do but the circuit won’t work properly!) If the leads do not protrude enough from the

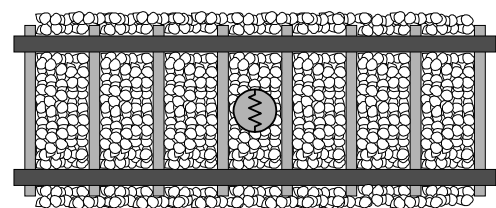

Figure 5 – photocell placement

underside of your layout then it will be necessary to extend the leads; soldering wires to them is the most common method; make sure you insulate any connections you make to the photocell leads so that they don’t short out. Once you have wired the photocells to the GCP and verified their operation you may wish to put a dab of white glue under the photocells to hold them in place; make sure you don’t get glue on the top surface of the photocells as this may prevent it from operating properly. Figure 6 illustrates the photocell wiring; make sure you have the photocells in the correct order as shown at the top of page 1. Photocells do not have any polarity so you can connect either lead to the GND terminal and connect the remaining lead to the appropriate photocell input. The spacing between the outer photocells (WF and EF) and inner photocells (WN and EN)

depends upon how long of an approach you wish to define for the crossing. However, keep in mind that there is a 35 second

timeout that the GCP uses. This means that if it takes more than 35 seconds for a train to cover the nearest inner photocell after uncovering an outer photocell then the GCP will think the train has actually backed up and exited the detection section!

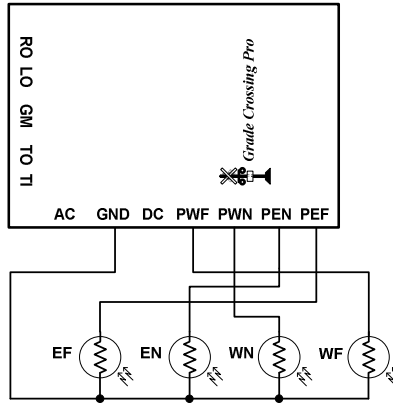

Figure 6 – photocell wiring

The photocells require a light source above them to function properly. On most layouts the room lighting should be sufficient. However, if any of the photocells are located in an area that doesn't get much overhead lighting or if you have simulated "nighttime" operations then it will be necessary to locate a light source on the layout near the photocell(s). Street lights and yard lights are common light sources. Locate the light source slightly to the left or right of the photocell(s) and not directly over it; this will allow the GCP to still properly detect a train that has stopped over a photocell with the gap between cars over the photocell.

Photocell sensitivity setup

You can adjust the sensitivity of each photocell on the circuit board using a small slotted head screwdriver. Along one edge of the board are four potentiometers (or "pots") that are labeled "WF", "WN", "EN" or "EF". The GCP supports a SETUP mode to make this adjustment process easier. To enable this mode, you must have the switch labeled SETUP in the ON/CLOSED position. In this mode the signals and gates will not operate. The GCP circuit board contains a red LED near the configuration switches; this LED will assist you in setting the photocell sensitivity. Now follow these steps:

1. Remove all obstacles that may be covering the photocells or blocking overhead light to them.
2. Insert the blade of the screwdriver (from the edge of the circuit board, not from the center of the board) into the adjustment pots, one at a time. Turn the screwdriver completely counter-clockwise (left) in all FOUR of the pots.
3. For the adjustment pot labeled WF turn the screwdriver clockwise (right) until the on-board LED just lights up. Then turn the screwdriver back counter-clockwise until the LED goes out.
4. Repeat step 3 for the three remaining pots.
5. Exit SETUP mode by putting the SETUP switch in the OFF/OPEN position. The crossing signals should now operate properly. It may be necessary to repeat this procedure if layout lighting conditions change significantly.

Turning the pots clockwise adjusts for brighter overhead lighting conditions while turning the pots counter-clockwise adjusts for dimmer overhead lighting.

Power

The GCP accepts AC or DC power (7 - 16V). Power consumption when used with LED-based signals is approximately 90mA; power consumption when using bulb-based signals is approximately 130mA. If you are only using a single GCP then use the TWO AC terminals to provide power (polarity doesn't matter); **do NOT connect AC power to the GND terminal!** You can use the AC or DC accessory terminals on your throttle/power pack provided the voltage doesn't exceed 16V. You can even power the circuit from the rails if you're using command control (e.g. DCC, Railcommand, etc); in this case use the AC IN terminals on the GCP. If you are using more than one GCP you can power them all from a single DC source as shown in Figure 7 below.

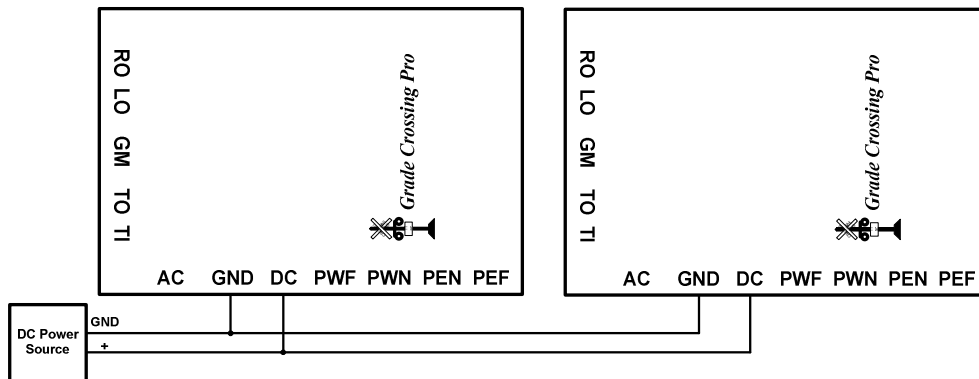

Figure 7 – DC power

Controlling an external bell ringer circuit

The “TO” (Trigger Output) terminal on the GCP can be used to trigger an external bell ringer circuit. The “TO” is active when the gate motor outputs are on; it is an “open collector, active low” output which means that it is at ~0V when on and looks like an open circuit when off. Figure 8 below illustrates how to control Innovative Train Technology’s HQ Series bell module. Note that you **MUST** use a DC power source and you **MUST** make those connections on the ITT module in the order shown. The leftmost terminal on the middle terminal block set on the ITT module is not used! When the GCP’s “TO” output is active it will trigger the ITT module. **Note that if you have an older ITT module (i.e. NOT marked 2009) then please contact us for details on connecting it to the GCP.**

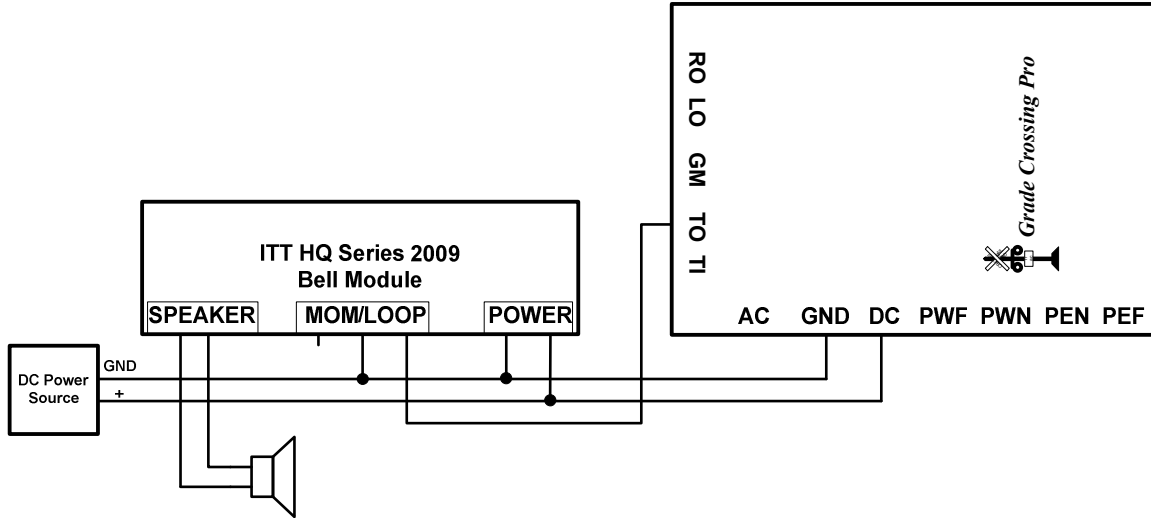
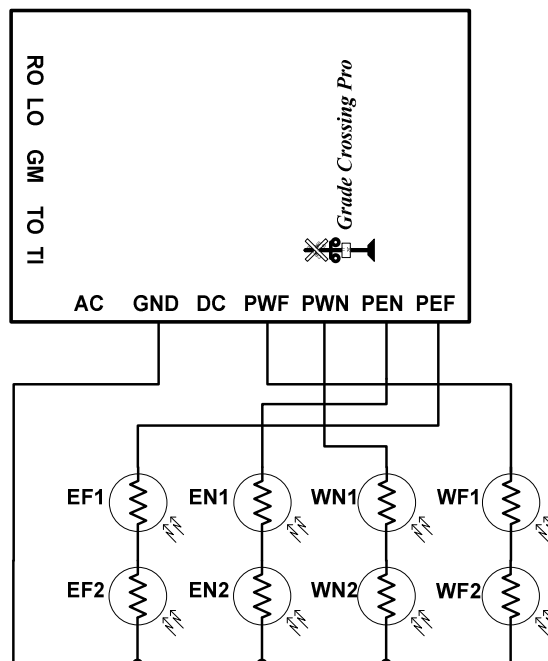

Figure 8 – Bell ringer control

Multi-track grade crossings

There is an obvious tendency to just add additional photocells to handle additional tracks when you have a multi-track grade crossing. The problem with this implementation is that the GCP cannot differentiate between two trains traveling in opposite directions on different tracks. As such it could easily get “confused” and not provide the prototypical sequencing (i.e. the action starts when the train covers a far photocell and the action stops when the train clears the near photocell on the other side of the crossing). If you will have multiple trains traveling through the crossing area (with outer boundaries defined by the far photocells) at the same time then you must use one GCP for each track. See the next section for details on how to cascade multiple GCPs. **IF you operate your trains such that only ONE train can possibly go through the crossing area at a time then you CAN simply add additional photocells (\$2.00 each; available from us) for the additional tracks.** In this implementation you will wire the additional photocells in series with their counterparts on adjacent tracks. Figure 9 below illustrates the photocell wiring for a two-track crossing.

Figure 9 – Photocell wiring for a RESTRICTED OPERATION two-track crossing



Cascading Multiple GCPs for multi-track grade crossings

The “TI” and “TO” terminals on the GCP are used for cascading multiple GCPs when you have a multi-track crossing. You must use one GCP per track and you **MUST** use the **SAME** DC power source (as shown in Figure 10 below) for all cascaded GCPs. You will denote **ONE** GCP as the “master” and the others as “slaves”. The **master provides detection for one track and receives “triggers” from the slaves and provides the signal and motor outputs**; the slaves only provide detection via their own photocells and **do not utilize their signal or motor outputs**. Figure 10 illustrates the wiring for a 3 track set up.

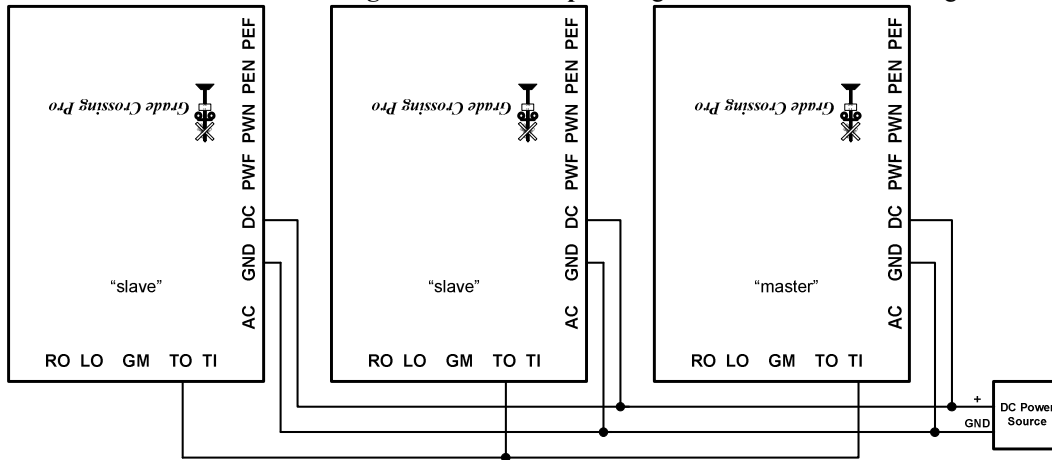
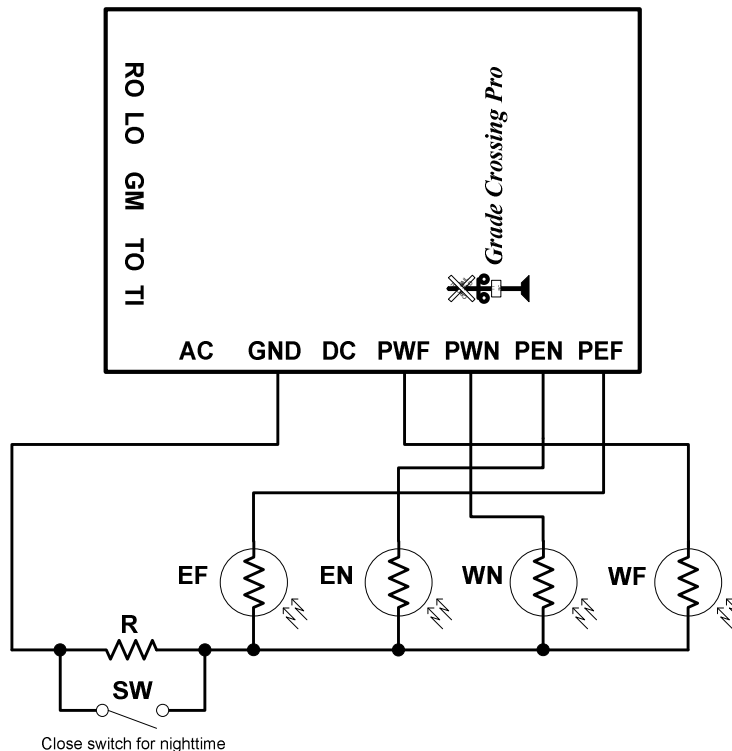

Figure 10 – Cascading Multiple GCPs

Handling “daytime” and “nighttime” operation

If you operate your layout under varying lighting conditions you certainly won’t want to have to adjust the photocell sensitivity each time you go from a high brightness (“daytime”) condition to a low brightness (“nighttime”) condition. The following diagram illustrates how you can provide **SOME** compensation for differing light levels. Note that this does **NOT** mean that the photocells will function in total darkness (i.e. no source of overhead or local lighting); if you operate in such an environment then you should consider replacing the photocells with infrared circuitry as covered on page 7.



When setting up the sensitivity of the GCP’s photocells you should do so under your “nighttime” condition; during this operation you must have the SPST switch (labeled SW in the drawing) in the **CLOSED** position thereby shorting out resistor R. Then during “daytime” operations you will **OPEN** switch SW thus allowing resistor R to become part of the photocell circuitry. The effect of resistor R is to increase the overall resistance of the photocell inputs thus mimicking the case where there is less light shining on them. Another way to look at it: lower light level means the photocells have a resistance higher than when the light level is higher. Thus, resistor R counteracts the lowering of photocell resistance when the light is higher.

The value of resistor R is difficult to predict but it is suggested that you start with a value of 1K ohm (a ¼ watt resistor is fine). You might need to lower this value depending upon the level of light on the photocells during “nighttime” operation.

Minimizing electrical noise effects from other sources that may cause false triggering

Switch machines, switch motors and electrical uncouplers are notorious for generating electrical noise when they are energized. Such noise can be inadvertently coupled onto the GCP's photocell connections which can then lead to false triggering of the signal circuit. The first remedy to try is to make sure that wiring for those devices is kept apart from the photocell wiring. This may not always be practical so adding decoupling/filter components to the GCP circuit will usually eliminate the false triggering. The following drawing illustrates what needs to be done. Note that capacitors C1 and C3 are polarized so make sure you connect them correctly; C2 has no polarity. Also, pay attention to the component location as outlined below in the parts list. The numbers in parentheses are Radio Shack part numbers. The drawing only shows one photocell. Each photocell will need its own "R1" and "C3" components; only one "C1" and "C2" are needed for each GCP. It may also be necessary to add filtering to the power source for the "offending" item. For example, if you are using switch motors powered by a DC (unipolar or bipolar) power source you may need to add filter capacitors to that power source. We suggest a 0.1uF/50V ceramic disk capacitor (such as C2 above) in parallel with a 100uF/35V electrolytic capacitor (similar to C1 above, but obviously a higher value). Connect them similar to the way C1 & C2 are connected in the drawing (i.e. positive lead to positive power output; negative lead to the negative power output or ground).

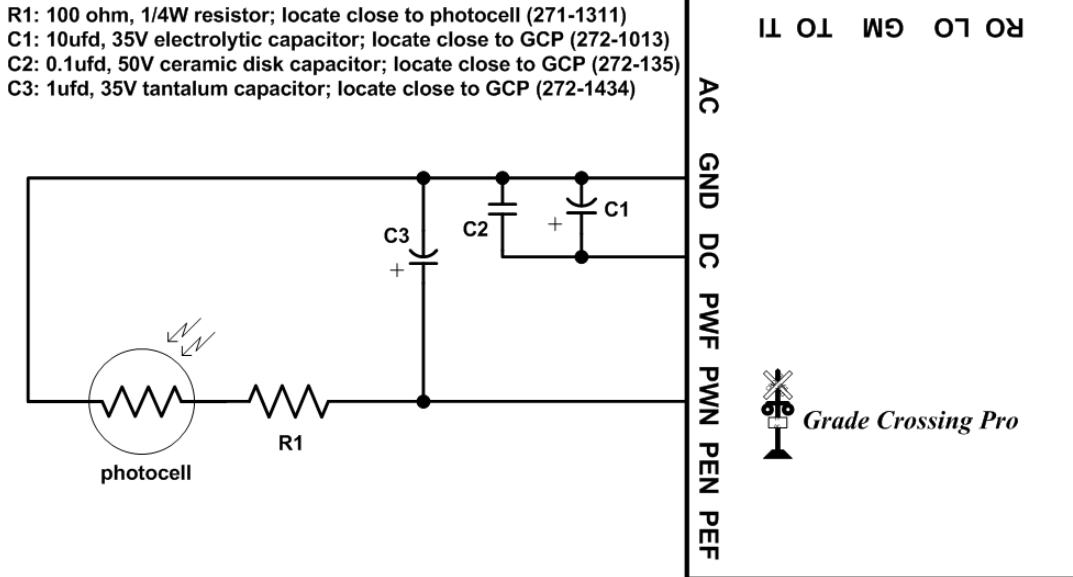

Finally, if noise problems still exist you may need to use coaxial cable for the photocell connections. Connect the shield of such a cable to GND terminal on the GCP and connect the center wire to the appropriate photocell terminal.

Using an infrared emitter and detector instead of the photocell

It is possible use infrared emitter and detector pairs instead of the photocells for train detection. The wiring for one photocell input is shown below. When the infrared beam is not obstructed from the detector the output of the detector will be approximately 0.2V. When the infrared beam is obstructed the output of the detector will essentially appear like an open circuit to the GCP's photocell inputs which will be interpreted like a covered photocell.

The value of the current-limiting resistor, R, must be calculated appropriately! Refer to the specification for the IR emitter (IR-E) to find its current consumption (I) and voltage forward (Vf) drop. The resistor value is then calculated using this formula: $R = (V_{DC} - V_f) / I$. For example, if I is 10mA (0.01 Amps), Vf is 2 volts and V_{DC} is 12 volts then $R = (12-2) / 0.01 = 1000$ ohms.

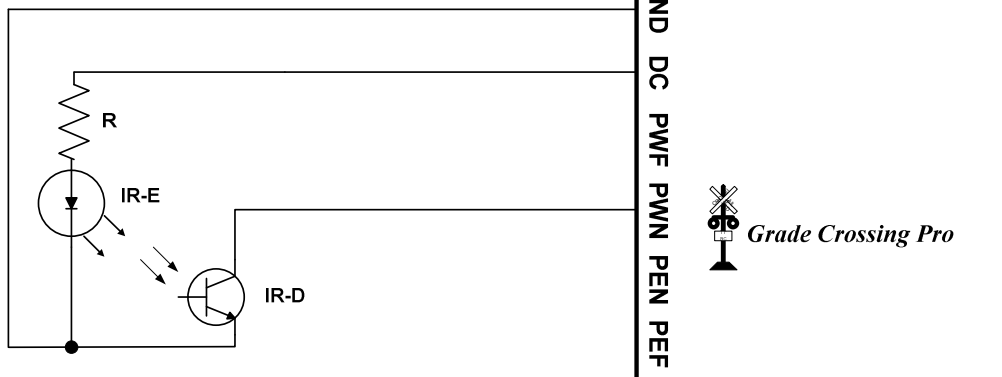

You may also want to consider "upgrading" your GCP to our IR version which includes IR components that mount between the rails similar to the photocells. The IR-KIT-GCP is only available directly from us.

Troubleshooting

If your signals do not flash when a particular photocell is covered or uncovered then you can perform the following tests. First, perform the photocell setup routine previously described. If one or more of the photocells does not function properly then you know it is faulty. If the photocells are OK then you might have a problem with the GCP, the signals, or the wiring between them.

If the red LED on the GCP board stays lit when the GCP is in SETUP mode then there is a problem with: photocell sensitivity, photocell wiring, overhead lighting level, photocell(s) or one of the chips on the GCP. First, make sure you have adequate overhead lighting. Second, double-check your photocell wiring. A missing photocell connection (missing wire or open circuit) will be interpreted by the GCP as a covered photocell. Next, put the GCP in SETUP mode (see page 1) and turn all four photocell sensitivity pots completely counter-clockwise (left). If the red LED goes out then simply complete the photocell setup process continuing with Step 3 on page 4. If the red LED is still lit then the problem is either a bad photocell or a faulty chip on the GCP. You can determine which is the case by TEMPORARILY connecting all four photocell inputs (PWF, PWN, PEN, PEF) to GND in ADDITION to leaving the correct photocell wiring in place. This is, in effect, shorting out the photocells and making them appear to have zero resistance. The GCP interprets this as having infinite light shining on the photocells. If the red LED goes out with these temporary connections in place then you have a bad photocell. You can determine which photocell is bad by removing the temporary connections one-at-a-time. If the red LED turns on when you remove a temporary connection from photocell input "X" then that photocell is the bad one. If the red LED stays lit even with all four temporary connections in place then you likely have a bad chip on the GCP. The chip that "processes" the photocell inputs is located closest to the photocell sensitivity pots. This chip is labeled "LM339". Replacements are available from us or you can purchase one from stores such as Radio Shack (part number 276-1712). To replace the chip you will need to gently pry it out of its socket using a flat blade screwdriver. Take great care when inserting the replacement chip so that you don't bend any of its pins underneath it. Make sure the text on the chip has the same orientation as the name "Grade Crossing Pro" on the circuit board.

Warranty

This product is warranted to be free from defects in materials or workmanship for a period of one year from the date of purchase. **Logic Rail Technologies** reserves the right to repair or replace a defective product. The product must be returned to **Logic Rail Technologies** in satisfactory condition. This warranty covers all defects incurred during normal use of this product. This warranty is void under the following conditions:

- 1) If damage to the product results from mishandling or abuse.
- 2) If the product has been altered in any way (e.g. soldering).
- 3) If the current or voltage limitations of the product have been exceeded.

Requests for warranty service must include a dated proof of purchase, a written description of the problem, and return shipping and handling (\$6.00 inside U.S./\$10.00 outside U.S. - U.S. funds only). Except as written above, no other warranty or guarantee, either expressed or implied by any other person, firm or corporation, applies to this product.

Technical Support

We hope the preceding instructions are sufficient for answering any questions you might have about the installation of this product. If you require technical support first contact your place of purchase for assistance. If you still need further assistance then please do not hesitate to contact us by phone, fax, mail and email; our contact information can be found on page 1.