

Getting started

Thank you for purchasing a *Logic Rail Technologies* product! Please familiarize yourself with all the instructions prior to installing this board. These instructions cover the version of the *Block Animator* that provides 3-aspect signaling for Tomar semaphore motors, bulb-based signals (including position light signals), and LED-based, common anode (positive) wired position light signals.

The *Block Animator* (BA) provides automatic operation of two 3-aspect block signals in a semi-prototypical way. Four photocells are used for bidirectional train detection. The layout of the signals (or semaphores) and photocells is illustrated below.

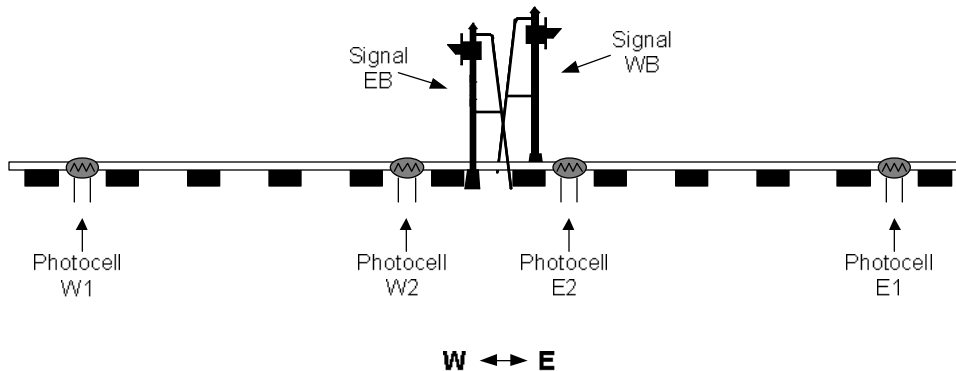

The BA operates the signals as described next. In the absence of any trains the two signals will be green. Now consider a train traveling eastbound. When photocell W1 is covered signal WB will change from green to red and will remain red as the train continues eastbound and subsequently covers signal E2. When the train then covers photocell W2 signal EB will change from green to red. Once the train has totally uncovered photocells W1 and E2 then signal WB will change from red back to green. As the train continues eastbound towards photocell E1 signal EB will remain red. Once the train has passed over photocell E1 and totally uncovers both it and photocell W2 signal EB will change to yellow; this mimics the behavior of the train entering the “next block.” After a time delay (10 or 30 seconds; see below) signal EB will change to green. Signal operation for a westbound train is similar with signal EB changing from green to red and back to green while signal WB changes from green to red to yellow and back to green.

You should make all of the connections to the BA before applying power to it. You can mount the BA anywhere it is convenient underneath your layout using the four mounting holes provided. The holes will accept #4 screws; do not enlarge the holes as damage to the circuit board can result and your warranty will be voided!

The BA board has a set of 6 configuration switches on it. Each switch is described below.

Switch Name	Meaning when OFF/OPEN	Meaning when ON/CLOSED
SETUP	BA is in normal operating mode	BA is in photocell setup mode
DELAY	Yellow to Green delay is 30 seconds	Yellow to Green delay is 10 seconds
SIG_EB	MUST use this setting	Do not use this setting
SIG_WB	MUST use this setting	Do not use this setting
YELHUE	Not used	Not used
APPRL	Approach Lighting is Disabled	Approach Lighting is Enabled

Approach Lighting

The concept of Approach Lighting is quite simple. A signal (excluding semaphores) remains dark (not illuminated) until a train approaches it (i.e. the block in advance of the signal is occupied). This has been primarily used in the western U.S. in remote locations where signal equipment operates on battery power. Having the signals unlit most of the time saves battery power as well as prolongs the life of the bulbs. The “rule” for illumination is simple: the signal shall be illuminated when the preceding block is occupied. The BA supports this feature (when the APPRL switch is ON/CLOSED) and works as follows. Signal EB will be illuminated whenever an eastbound train covers photocell W1 and will keep signal EB illuminated until photocell E2 is covered and then subsequently uncovered. Note that if the eastbound train covers and then uncovers photocell W1 but after 35 seconds hasn’t covered photocell E2, then the BA will assume the train has actually reversed direction and will turn the signal off. Similarly, signal EB will also be illuminated whenever a westbound train covers photocell E2 and will keep signal EB illuminated until photocell W1 is covered and then subsequently uncovered. The same 35 second “timeout” mechanism is in effect for this direction of travel too. Signal WB will operate in a similar manner with respect to photocells E1 and W2. You can turn approach lighting on or off at any time. Hopefully it is obvious that if you turn this feature off then the signals will be illuminated all the time!

Semaphore motor and signal wiring

Wiring for Tomar's semaphore motor and signal is shown in Figure 1. You will need a current limiting resistor for the semaphore bulb; refer to Tomar's instruction sheet for details. **Note that the input power range must be 9 - 12V AC or DC.** The C terminal is not used with this signal type!

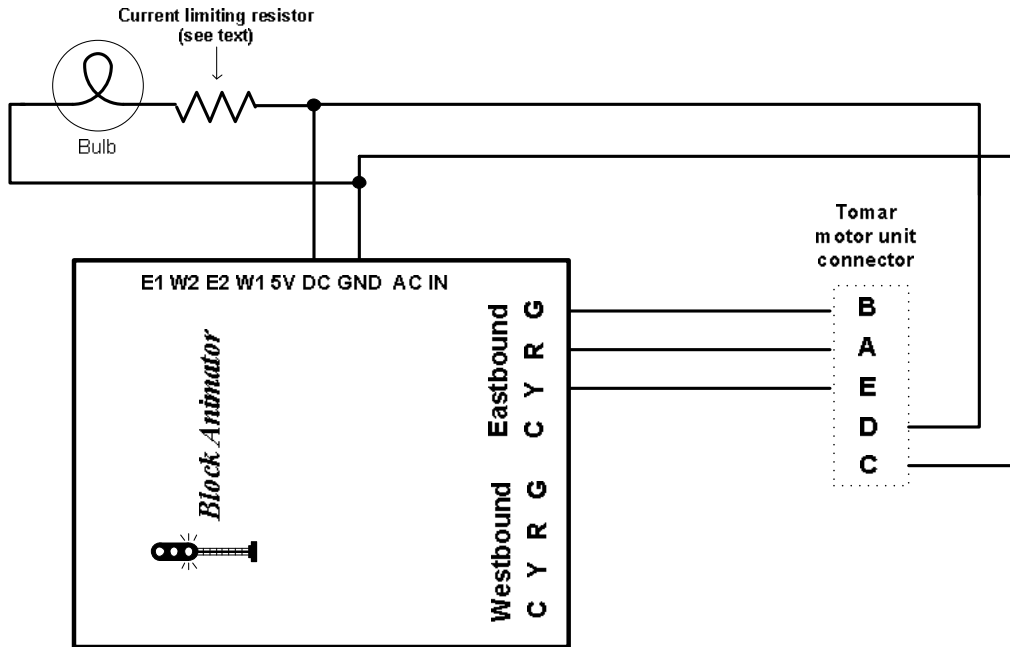

Figure 1 – Semaphore motor and signal

3-light signal wiring

Wiring for 3-light bulb-based light signals is shown in Figure 2 below. You will need the current limiting resistors if the voltage rating of the bulbs is lower than the input voltage to the BA. For example, if the input voltage is 16V and the bulbs are rated at 12V (get this information from the manufacturer of the signal) then we would suggest a resistor value of 100 ohms (e.g Radio Shack #RSU 11345519). If the input voltage is equal to or slightly lower than that of the bulbs then no resistors are needed. **NOTE: The C terminal is not used with this signal type!**

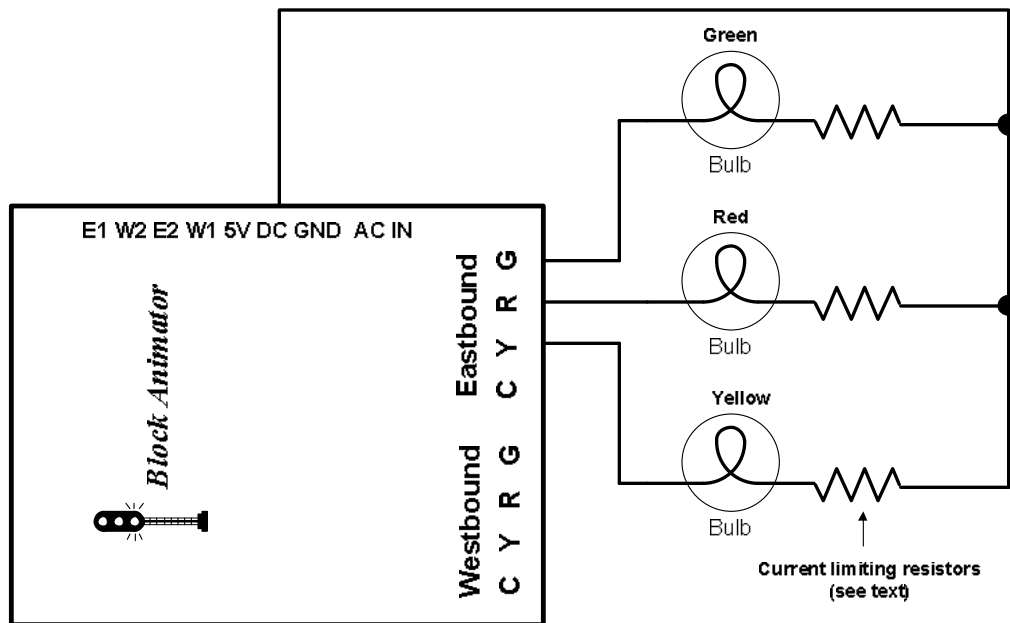

Figure 2 – 3-light bulb-based signal

If your signal is an “absolute” type (that means it has two red bulbs for the stop position while all others are yellow) then you will have to cut the exposed lead on the diode (D9 for the EASTBOUND signal or D12 for the WESTBOUND signal) on the **BA** board as shown in Figure 5. Use a pair of diagonal cutters to make the cut. Be sure that the two cut ends no longer touch each other by separating them slightly. Failure to do so won’t cause any damage but it may cause the center yellow bulb to illuminate when the signal is in the stop position.

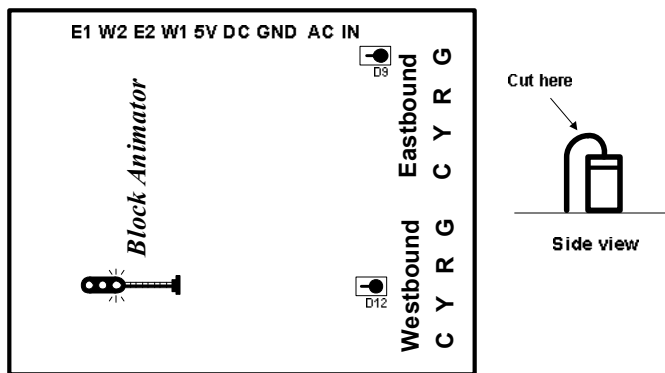

Figure 5 – cutting diodes for absolute type signals

LED-based Position Light Signals (common anode wiring)

The position light signal head is shown as a circle on the right-hand side of the drawing in Figure 6 below. Within the signal head are the seven LED “lights”; if you have a B&O style color position light signal then it will not have a center LED. The value of the current limiting resistors depends upon the value of the input voltage to the Signal Animator. For a 16V input voltage we recommend a resistor value of either 390 ohms (e.g. Radio Shack # 271-1114) or 330 ohms (e.g. Radio Shack #271-1113); you should use ½ watt resistors. Use a higher value for the center LED; we recommend a value of 680 ohms (e.g. Radio Shack #271-1117).

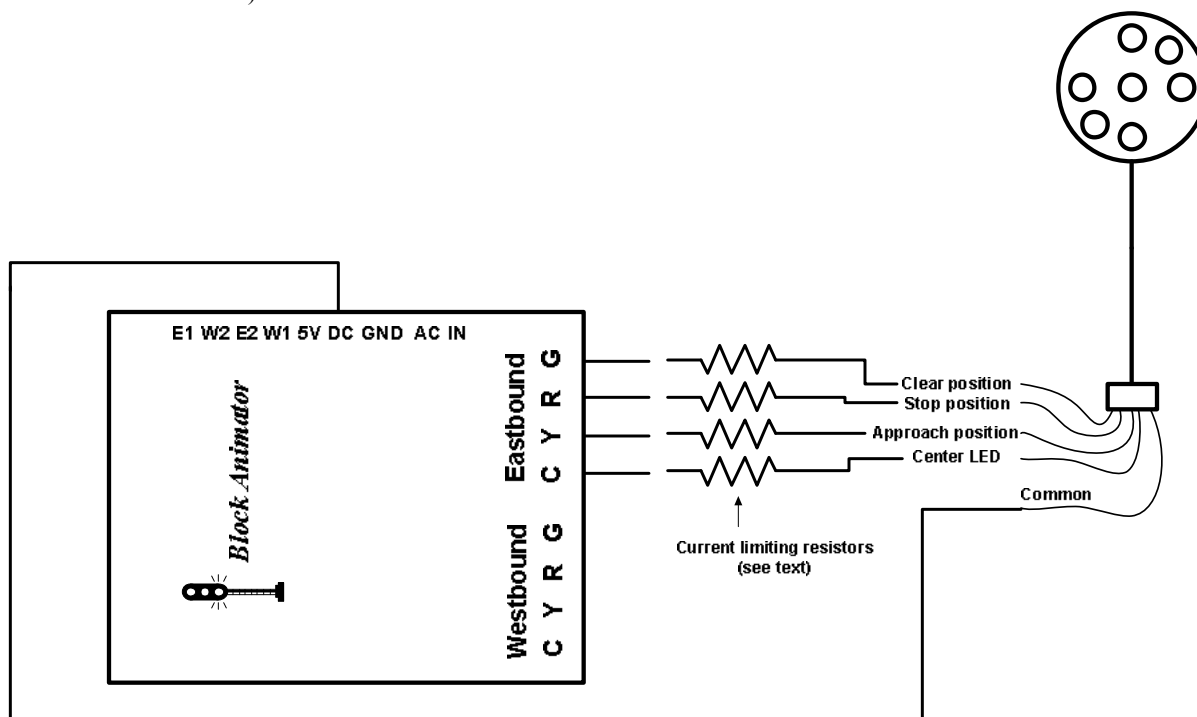

Figure 6 – LED-based (common cathode wiring) position light signals

If your signal(s) is an “absolute” type (that means it has two red LEDs for the stop position while all others are yellow) then you will have to cut the exposed lead on the appropriate diodes on the **BA** board as shown in Figure 5 above. Use a pair of diagonal cutters to make the cut. Be sure that the two cut ends no longer touch each other by separating them slightly. Failure to do so won’t cause any damage but it may cause the center yellow LED to illuminate when the signal is in the stop position.

The Photocells

The photocells should be mounted between the rails. Drill a 9/64" hole through the ballast, roadbed, and sub-roadbed. For the smaller scales this drilling may end up hitting the ties. Take your time so you don't mangle them! Figure 7 illustrates the placement of a photocell in between the rails. Insert the leads of the photocell into the hole from the top of your layout. One of the photocell leads has a piece of insulation on it so be sure the two leads don't touch each other (you won't damage anything if they do but the circuit won't work properly!) If the leads do not protrude enough from the underside of your layout then it will be necessary to extend the leads; soldering wires to them is the most common method; make sure you insulate any connections you make to the photocell leads so that they don't short out. Once you have wired the photocells to the **BA** and verified their operation you may wish to put a dab of white glue under the photocells to hold them in place; make sure you don't get glue on the top surface of the photocells as this may prevent it from operating properly. Figure 8 illustrates the photocell wiring; make sure you have the photocells in the correct order as shown at the top of page 1. Photocells do not have any polarity so you can connect either lead to the GND terminal and connect the remaining lead to the appropriate photocell input. The spacing between the outer photocells (W1 and E1) and inner photocells (E2 and W2) depends upon how long of a signal "block" you wish to define for each signal. However, keep in mind that there is a 35 second timeout that the **BA** uses. This means that if it takes more than 35 seconds for a train to cover the nearest inner photocell after uncovering an outer photocell then the **BA** will think the train has actually backed up and exited the block!

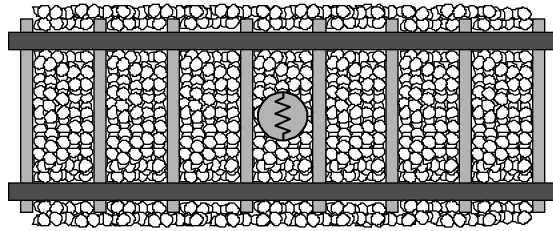

Figure 7 – photocell placement

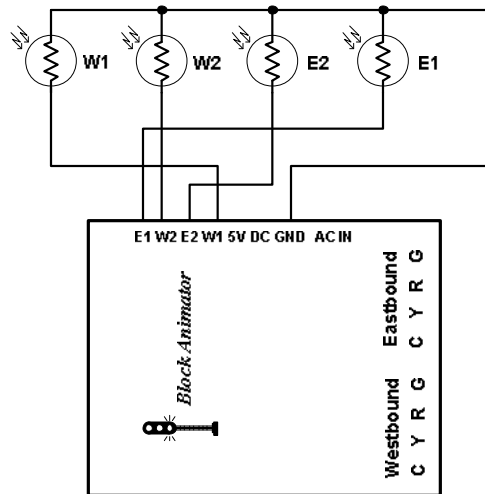

Figure 8 – photocell wiring

The photocells require a light source above them to function properly. On most layouts the room lighting should be sufficient. However, if any of the photocells are located in an area that doesn't get much overhead lighting or if you have simulated "nighttime" operations then it will be necessary to locate a light source on the layout near the photocell(s). Street lights and yard lights are common light sources. Locate the light source slightly to the left or right of the photocell(s) and not directly over it; this will allow the **BA** to still properly detect a train that has stopped over a photocell with the gap between cars over the photocell.

Photocell sensitivity setup

You can adjust the sensitivity of each photocell on the circuit board using a small slotted head screwdriver. Along one edge of the board are four potentiometers (or "pots") that are labeled "W1", "E2", "W2" or "E1". The **BA** supports a SETUP mode to make this adjustment process easier. To enable this mode, you must have the switch labeled SETUP in the ON/CLOSED position. In this mode the signals will not change colors. The **BA** circuit board contains a red LED near the configuration switches; this LED will assist you in setting the photocell sensitivity. Now follow these steps:

1. Remove all obstacles that may be covering the photocells or blocking overhead light to them.
2. Insert the blade of the screwdriver (from the edge of the circuit board, not from the center of the board) into the adjustment pots, one at a time. Turn the screwdriver completely counter-clockwise (left) in all FOUR of the pots.
3. For the adjustment pot labeled W1 turn the screwdriver clockwise (right) until the on-board LED just lights up. Then turn the screwdriver back counter-clockwise until the LED goes out.
4. Repeat step 3 for the three remaining pots.
5. Exit SETUP mode by putting the SETUP switch in the OFF/OPEN position. The signals should now operate properly. It may be necessary to repeat this procedure if layout lighting conditions change significantly.

Turning the pots clockwise adjusts for brighter overhead lighting conditions while turning the pots counter-clockwise adjusts for dimmer overhead lighting.

Signal delay

The signal color delay (when the signal changes from yellow to green) can be either 10 seconds or 30 seconds. Choose the value based on your own personal preference. To select 10 seconds the configuration switch labeled DELAY must be ON/CLOSED; for 30 seconds the switch must be OFF/OPEN. You can change this as you wish even when the power to the BA is on.

Power

The BA accepts AC or DC power (7 - 16V); however, if you're using semaphore motors then the input power should be no higher than 12V. Power consumption is approximately 125mA (including the signals). If you are only using a single BA then use the AC IN terminals to provide power (polarity doesn't matter). You can use the AC or DC accessory terminals on your throttle/power pack provided the voltage doesn't exceed 16V. You can even power the circuit from the rails if you're using command control (e.g. DCC, Railcommand, etc); in this case use the AC IN terminals on the BA. If you are using more than one BA you can power them all from a single DC source as shown in Figure 9 below.

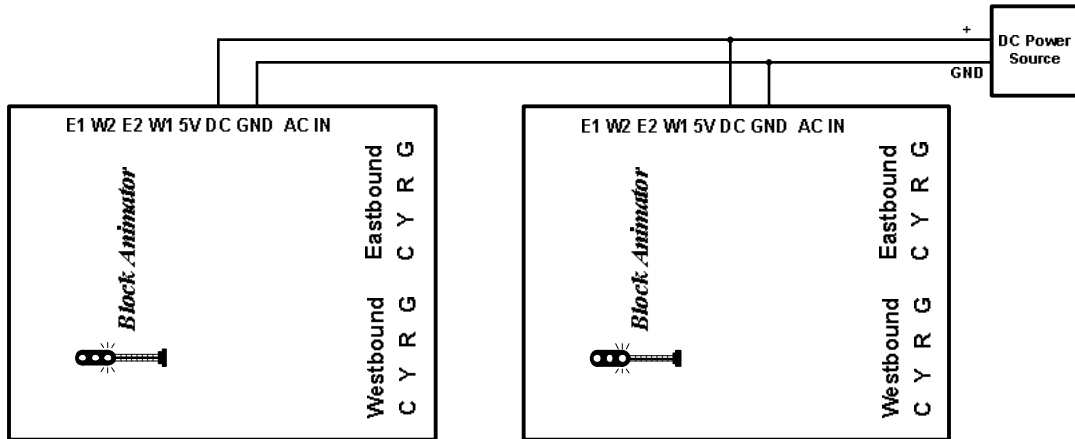

Figure 9 – DC power

Other Applications

Please contact us if you are interested in knowing how to interlock your signal (i.e. force it to red) with the position of a turnout or if you are interested in controlling a dual head signal with two *Block Animators*. We have an instruction supplement that covers these applications as well as illustrates use of the *Block Animator* with the signals arranged as opposite ends of a long section of track. You can also access this documentation online from our website at http://www.logicrailtech.com/lrt_docs.htm.

Minimizing electrical noise effects from other sources that may cause false triggering

Switch machines, switch motors and electrical uncouplers are notorious for generating electrical noise when they are energized. Such noise can be inadvertently coupled onto the BA's photocell connections which can then lead to false triggering of the signal circuit. The first remedy to try is to make sure that wiring for those devices is kept apart from the photocell wiring. This may not always be practical (especially if you're interlocking the signal head(s) with turnout position as described above). If that's the case, adding decoupling/filter components to the BA circuit will usually eliminate the false triggering. The drawing below illustrates what needs to be done. Note that capacitors C1 and C3 are polarized so make sure you connect them correctly; C2 has no polarity. Also, pay attention to the component location as outlined below in the parts list. The numbers in parentheses are Radio Shack part numbers. The drawing only shows one photocell. Each photocell will need its own "R1" and "C3" components; only one "C1" and "C2" are needed for each BA.

- R1: 100 ohm, 1/4W resistor; locate close to photocell (271-1311)
- C1: 10ufd, 35V electrolytic capacitor; locate close to BA (272-1013)
- C2: 0.1ufd, 50V ceramic disk capacitor; locate close to BA (272-135)
- C3: 1ufd, 35V tantalum capacitor; locate close to BA (272-1434)

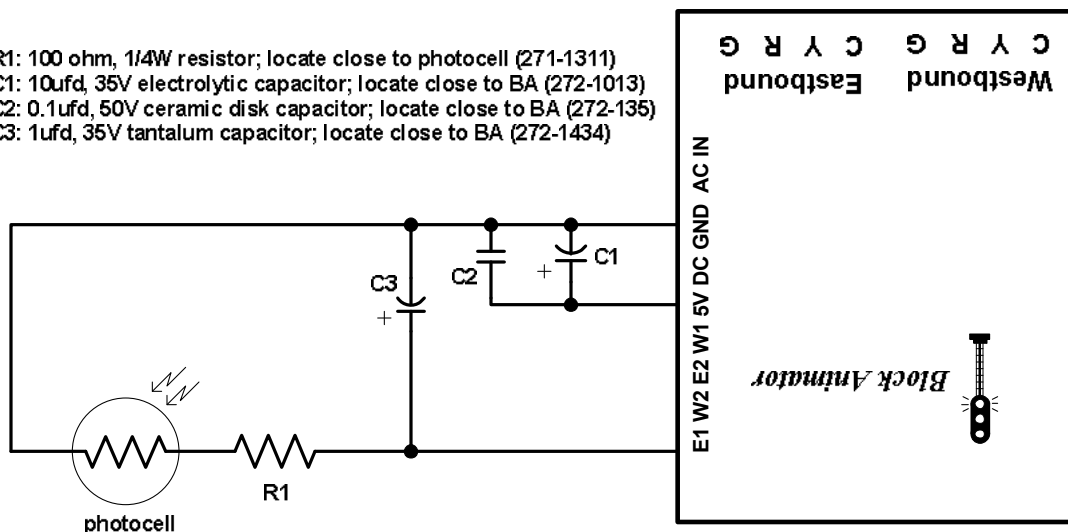

It may also be necessary to add filtering to the power source for the “offending” item. For example, if you are using switch motors powered by a DC (unipolar or bipolar) power source you may need to add filter capacitors to that power source. We suggest a 0.1ufd/50V ceramic disk capacitor (such as C2 above) in parallel with a 100ufd/35V electrolytic capacitor (similar to C1 above, but obviously a higher value). Connect them similar to the way C1 & C2 are connected above (i.e. positive lead to positive power output; negative lead to the negative power output or ground).

Finally, if noise problems still exist you may need to use coaxial cable for the photocell connections. Connect the shield of such a cable to GND terminal on the **BA** and connect the center wire to the appropriate photocell terminal.

Using an infrared emitter and detector instead of the photocell

It is possible use infrared emitter and detector pairs instead of the photocells for train detection. The wiring for one photocell input is shown below. When the infrared beam is not obstructed from the detector the output of the detector will be approximately 0.2V. When the infrared beam is obstructed the output of the detector will essentially appear like an open circuit to the **BA**'s photocell inputs which will be interpreted like a covered photocell.

The value of the current-limiting resistor, R, must be calculated appropriately! Refer to the specification for the IR emitter (IR-E) to find its current consumption (I) and voltage forward (Vf) drop. The resistor value is then calculated using this formula: $R = (5 - Vf)/I$. For example, if I is 10mA (0.01 Amps) and Vf is 2 volts then $R = (5-2)/0.01 = 300$ ohms; use a commercially available value such as 330 ohms.

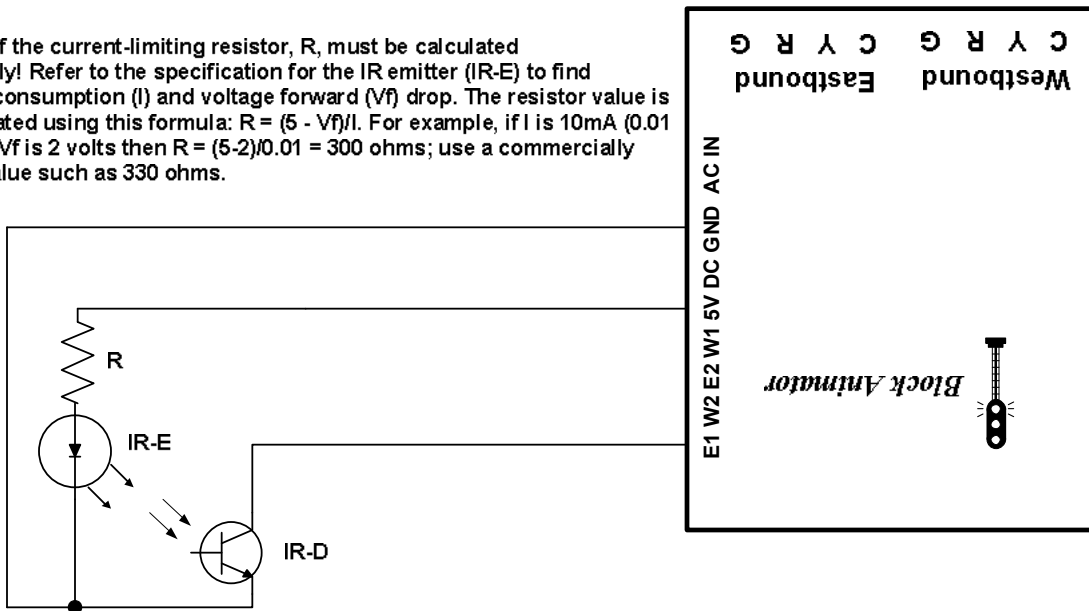

Warranty

This product is warranted to be free from defects in materials or workmanship for a period of one year from the date of purchase. **Logic Rail Technologies** reserves the right to repair or replace a defective product. The product must be returned to **Logic Rail Technologies** in satisfactory condition. This warranty covers all defects incurred during normal use of this product. This warranty is void under the following conditions:

- 1) If damage to the product results from mishandling or abuse.
- 2) If the product has been altered in any way (e.g. soldering).
- 3) If the current or voltage limitations of the product have been exceeded.

Requests for warranty service must include a dated proof of purchase, a written description of the problem, and return shipping and handling (\$4.00 inside U.S./\$8.00 outside U.S. - U.S. funds only). Except as written above, no other warranty or guarantee, either expressed or implied by any other person, firm or corporation, applies to this product.

Troubleshooting

If your signal is not reacting properly when a particular photocell is covered or uncovered then you can perform the following tests. First, perform the photocell setup routine previously described. If one or more of the photocells does not function properly then you know it/they is/are faulty. If the photocells are determined to be OK then you might have a problem with the **BA**, the signal, or the wiring between them.

Technical Support

We hope the preceding instructions are sufficient for answering any questions you might have about the installation of this product. However, technical support is available should you need it. We would ask that you first contact your place of purchase for assistance. If you still need further assistance then please do not hesitate to contact us. You can reach us via phone, fax, mail and email; our contact information can be found on the top of page 1.