

Getting started

Thank you for purchasing a *Logic Rail Technologies* product! Please familiarize yourself with all the instructions prior to installing this board. This version of the **Block Animator** (model BA-1) provides 3-color signaling for LED-based 3-light (common anode/positive) and searchlight-style signals. It can also be used with LED-based 2-light (common anode/positive) signals; of course then you'll only get 2-color signaling.

The **Block Animator** (BA) provides automatic operation of two 3-color block signals in a semi-prototypical way. Four pairs of Infrared (IR) emitters and detectors are used for bidirectional train detection. Detection is achieved when the IR beam from the emitter reflects off the underside of the train back down to the detector. **This version of the BA must be powered from either a 7-9V AC or 9-12V DC power source (such as our 12VPSR). Do NOT exceed these limits!** The layout of the signals and IR components is illustrated at left below; the illustration on the right is a side view of the IR detection method.

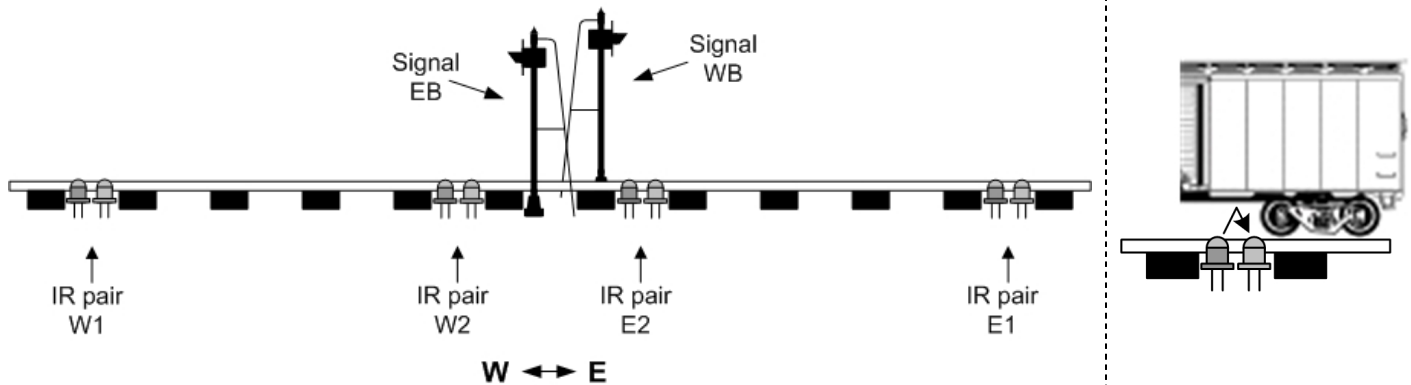

The **BA** operates the signals as described next. In the absence of any trains the two signals will be green. Now consider a train traveling eastbound. When sensor W1 is activated signal WB will change from green to red and will remain red as the train continues eastbound and subsequently activates sensor W2. When the train then activates sensor E2 signal EB will change from green to red. Once the train has totally cleared sensors W1 and W2 then signal WB will change from red back to green. As the train continues eastbound towards sensor E1 signal EB will remain red. Once the train has passed over sensor E1 and totally clears both it and sensor E2 signal EB will change to yellow; this mimics the behavior of the train entering the "next block." After a time delay (10 or 30 seconds; see below) signal EB will change to green. Signal operation for a westbound train is similar with signal EB changing from green to red and back to green while signal WB changes from green to red to yellow and back to green.

You should make all of the connections to the **BA** before applying power to it. You can mount the **BA** anywhere it is convenient underneath your layout using the four mounting holes provided. The holes will accept #4 screws; do not enlarge the holes as damage to the circuit board can result and your warranty will be voided!

The **BA** board has a set of 6 configuration switches on it. Each switch is described below.

Switch Name	Meaning when OFF/OPEN	Meaning when ON/CLOSED
SETUP	BA is in normal operating mode	BA is in sensor setup mode
DELAY	Yellow to Green delay is 30 seconds	Yellow to Green delay is 10 seconds
SIG_EB	MUST use this setting	Do not use this setting
SIG_WB	MUST use this setting	Do not use this setting
YELHUE	Not used	Not used
APPRL	Approach Lighting is Disabled	Approach Lighting is Enabled

Approach Lighting

The concept of Approach Lighting is quite simple. A signal remains dark (not illuminated) until a train approaches it (i.e. the block in advance of the signal is occupied). This has been primarily used in the western U.S. in remote locations where signal equipment operates on battery power. Having the signals unlit most of the time saves battery power as well as prolongs the life of the bulbs. The "rule" for illumination is simple: the signal shall be illuminated when the preceding block is occupied. The **BA** supports this feature (when the APPRL switch is ON/CLOSED) and works as follows. Signal EB will be illuminated whenever an eastbound train activates sensor W1 and will keep signal EB illuminated until sensor E2 is activated and then subsequently cleared. Note that if the eastbound train activates and then clears sensor W1 but after 35 seconds hasn't activated sensor E2, then the **BA** will assume the train has actually reversed direction and will turn the signal off. Similarly,

signal EB will also be illuminated whenever a westbound train activates sensor E2 and will keep signal EB illuminated until sensor W1 is activated and then subsequently cleared. The same 35 second “timeout” mechanism is in effect for this direction of travel too. Signal WB will operate in a similar manner with respect to sensors E1 and W2. You can turn approach lighting on or off at any time. Hopefully it is obvious that if you turn this feature off then the signals will be illuminated all the time!

Semaphore motor and signal wiring

Wiring for Tomar’s semaphore motor and signal is shown in Figure 1. You will need a current limiting resistor for the semaphore bulb; refer to Tomar’s instruction sheet for details. The input voltage will affect the speed of the turnout motor. The C terminal is not used with this signal type!

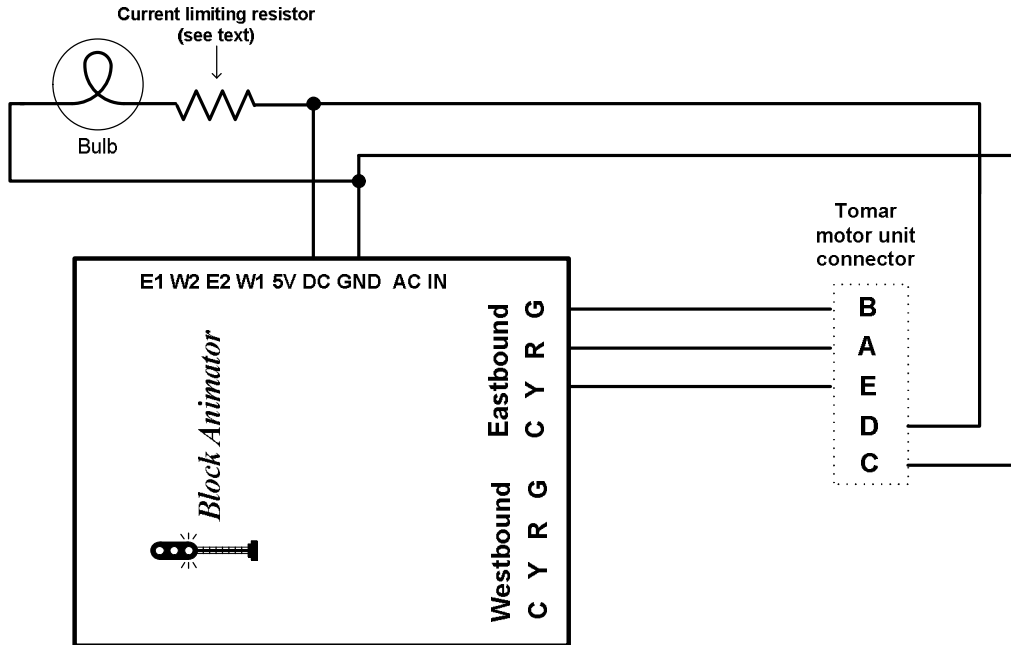

Figure 1 – Semaphore motor and signal

3-light bulb-based signal (e.g. NJ International) wiring

Wiring for 3-light bulb-based light signals is shown in Figure 2. You will need the current limiting resistors if the voltage rating of the bulbs is lower than the input voltage to the BA. For example, if the input voltage is 12V and the bulbs are rated at 1.5V (get this information from the manufacturer of the signal) then we would suggest a resistor value of 330 ohms, 1/2W (e.g Radio Shack #RSU 271-1113). If the input voltage is equal to or slightly lower than that of the bulbs then no resistors are needed. **NOTE: The C terminal is not used with this signal type!**

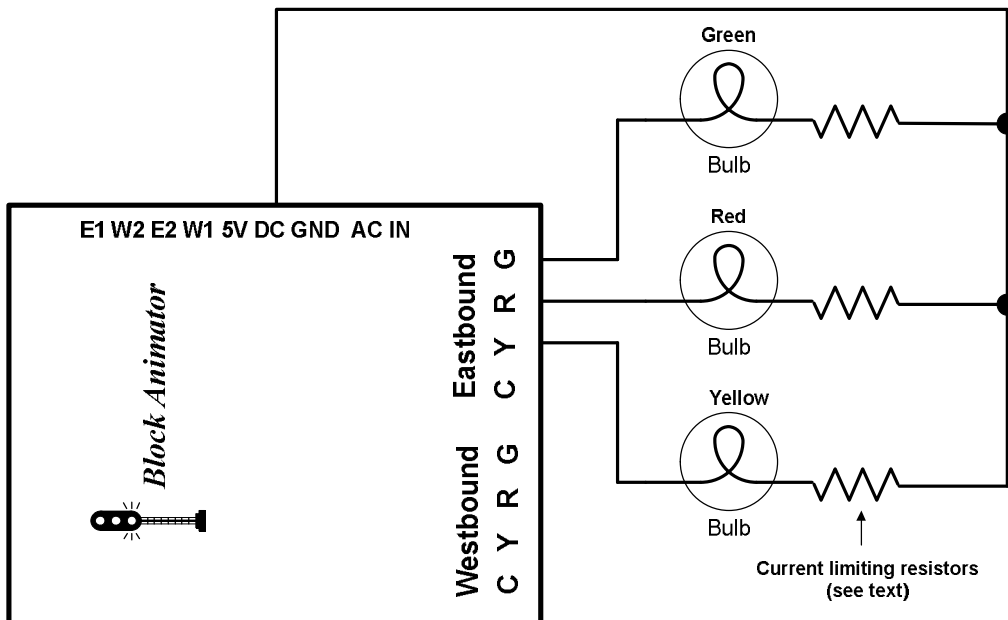

Figure 2 – 3-light bulb-based signal

2-light signal wiring

Wiring for 2-light bulb-based light signals is shown in Figure 3. Three diodes (e.g. Radio Shack #276-1101) must be added to the yellow and green outputs as shown. You will need the current limiting resistors if the voltage rating of the bulbs is lower than the input voltage to the **BA**. For example, if the input voltage is 12V and the bulbs are rated at 1.5V (get this information from the manufacturer of the signal) then we would suggest a resistor value of 330 ohms, 1/2W (e.g Radio Shack #RSU 271-1113). If the input voltage is equal to or slightly lower than that of the bulbs then no resistors are needed. NOTE: The C terminal is not used with this signal type!

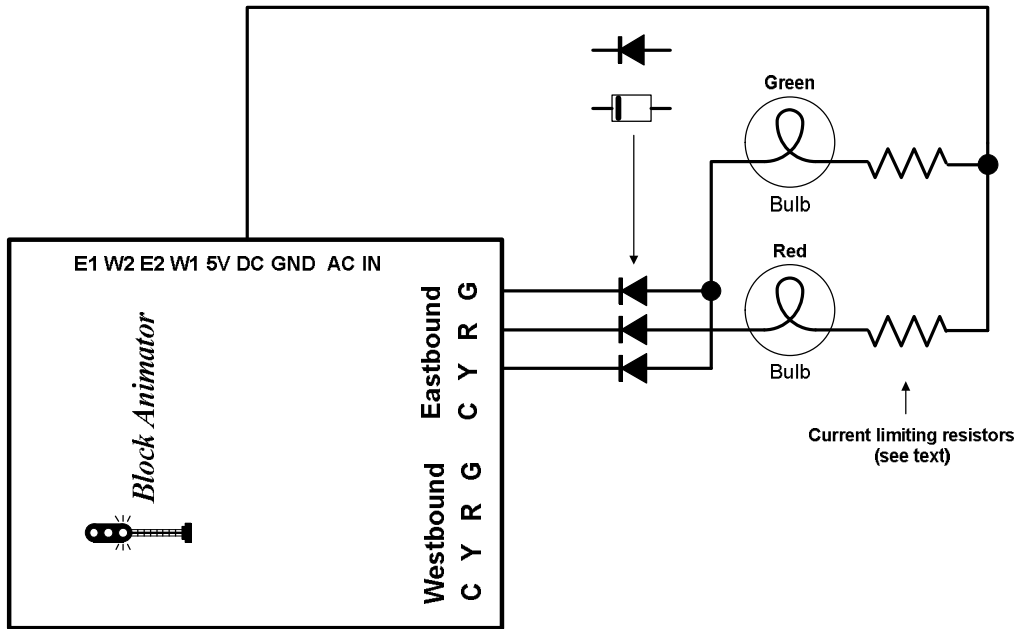

Figure 3 – 2-light bulb-based signal

Bulb-based Position Light Signals (e.g. NJ International)

Wiring for bulb-based position light signals is shown in Figure 4 below. You will need the current limiting resistors if the voltage rating of the bulbs is lower than the input voltage to the **BA**. You will need the current limiting resistors if the voltage rating of the bulbs is lower than the input voltage to the **BA**. For example, if the input voltage is 12V and the bulbs are rated at 1.5V (get this information from the manufacturer of the signal) then we would suggest a resistor value of 330 ohms, 1/2W (e.g Radio Shack #RSU 271-1113). If the input voltage is equal to or slightly lower than that of the bulbs then no resistors are needed.

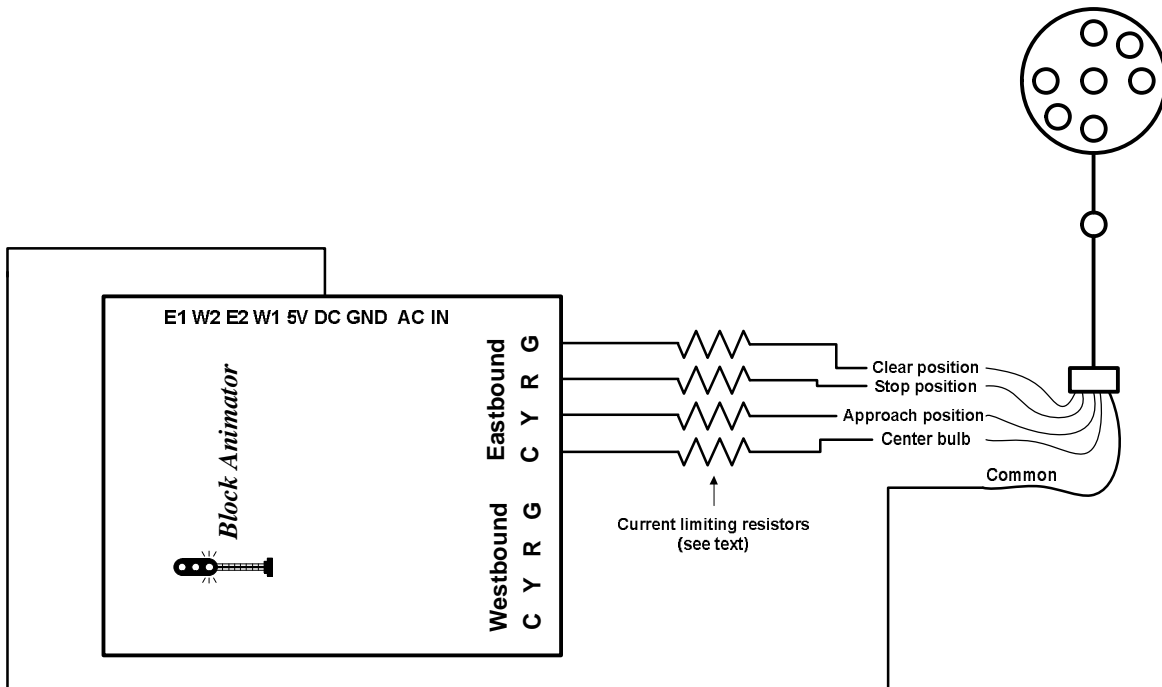

Figure 4 – Bulb-based position light signals

If your signal is an “absolute” type (that means it has two red bulbs for the stop position while all others are yellow) then you will have to cut the exposed lead on the diode (D9 for the EASTBOUND signal or D12 for the WESTBOUND signal) on the **BA** board as shown in Figure 5. Use a pair of diagonal cutters to make the cut. Be sure that the two cut ends no longer touch each other by separating them slightly. Failure to do so won’t cause any damage but it may cause the center yellow bulb to illuminate when the signal is in the stop position.

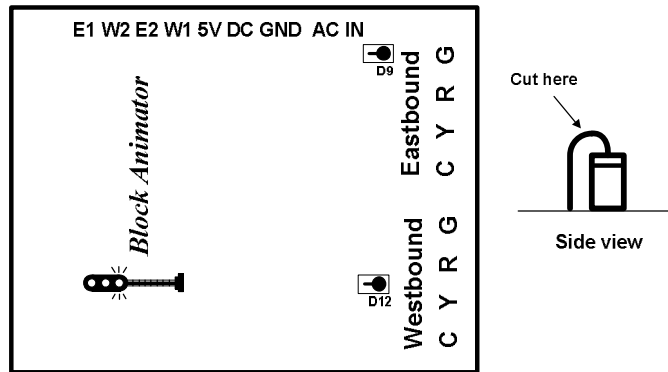

Figure 5 – cutting diodes for absolute type signals

LED-based Position Light Signals (common anode wiring)

The position light signal head is shown as a circle on the right-hand side of the drawing in Figure 6. Within the signal head are the seven LED “lights”; if you have a B&O style color position light signal then it will not have a center LED and you will not use the C terminal on the **BA**. The value of the current limiting resistors depends upon the value of the input voltage to the Signal Animator. For a 9V AC or 12V DC input voltage we recommend a resistor value of 330 ohms, 1/2W (e.g. Radio Shack #271-1113). Use a higher value for the center LED; we recommend a value of 680 ohms (e.g. Radio Shack #271-1117).

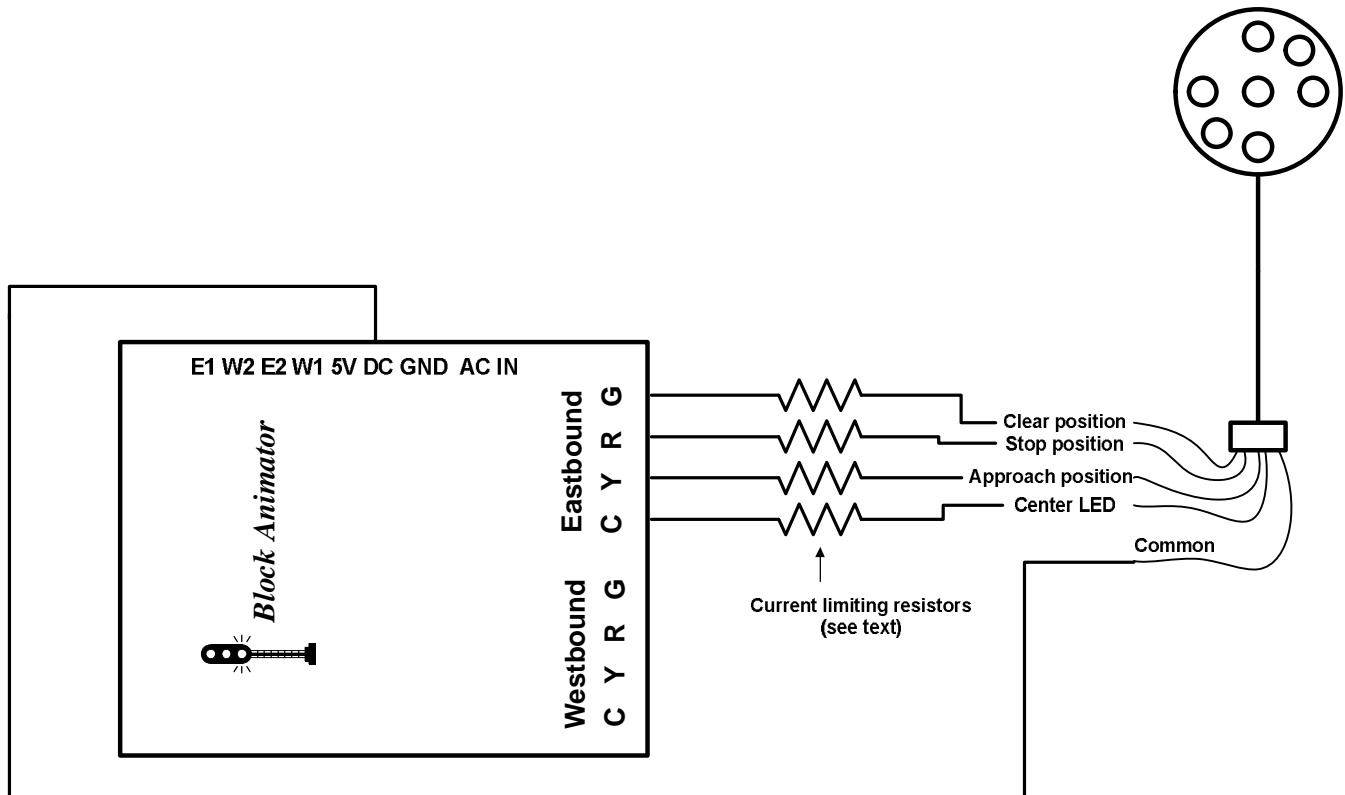

Figure 6 – LED-based (common anode wiring) position light signals

If your signal(s) is an “absolute” type (that means it has two red LEDs for the stop position while all others are yellow) then you will have to cut the exposed lead on the appropriate diodes on the **BA** board as shown in Figure 5 above. Use a pair of diagonal cutters to make the cut. Be sure that the two cut ends no longer touch each other by separating them slightly. Failure to do so won’t cause any damage but it may cause the center yellow LED to illuminate when the signal is in the stop position.

Mounting and wiring the IR components

The IR components should be mounted between the rails. Drill two 11/64" holes, approximately 1/4" apart, through the ballast, roadbed, and sub-roadbed. For the smaller scales this drilling may end up hitting the ties. Take your time so you don't mangle them! Figure 7a illustrates the suggested placement of the IR components between the rails; you may also locate them a tie apart from each other (Figure 7b). Insert the leads of one IR emitter (white and black wires) into one of the holes (it doesn't matter which one!) from the top of your layout. Repeat for the IR detector (blue and black wires). The tops of the components should sit no higher than the top of your ballast for optimal IR performance; in some cases (e.g. false triggering) it may be necessary to locate the components a little below the ballast line. You can extend the leads with similar (or larger) wire. We recommend soldering and insulating these connections. Once you have wired the IR components and verified their operation you may wish to put a dab of white glue or silicone caulk where the wires exit the holes underneath the layout. This will help to hold the components in place; make sure you don't get any substance (e.g. ballast or glue) on the top surface of the IR components as this may prevent them from operating properly. The spacing between the outer sensors (W1 and E1) and inner sensors (E2 and W2) depends upon how long of a signal "block" you wish to define for each signal. However, keep in mind that there is a 35 second timeout that the **BA** uses. This means that if it takes more than 35 seconds for a train to activate the nearest inner sensor after clearing an outer sensor then the **BA** will think the train has actually backed up and exited the block!

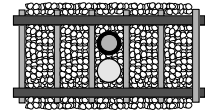

Figure 7a

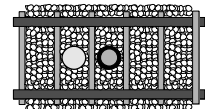

Figure 7b

Figure 8 below illustrates the wiring for one set of IR components (shown for sensor location "E1"). Replicate the same wiring for the three remaining sensor inputs. Four 150 ohm 1 Watt resistors are included with the **BA**. When properly wired the emitter will have a very faint red glow coming from it. You can also look at the emitter through a digital camera and see the infrared light!

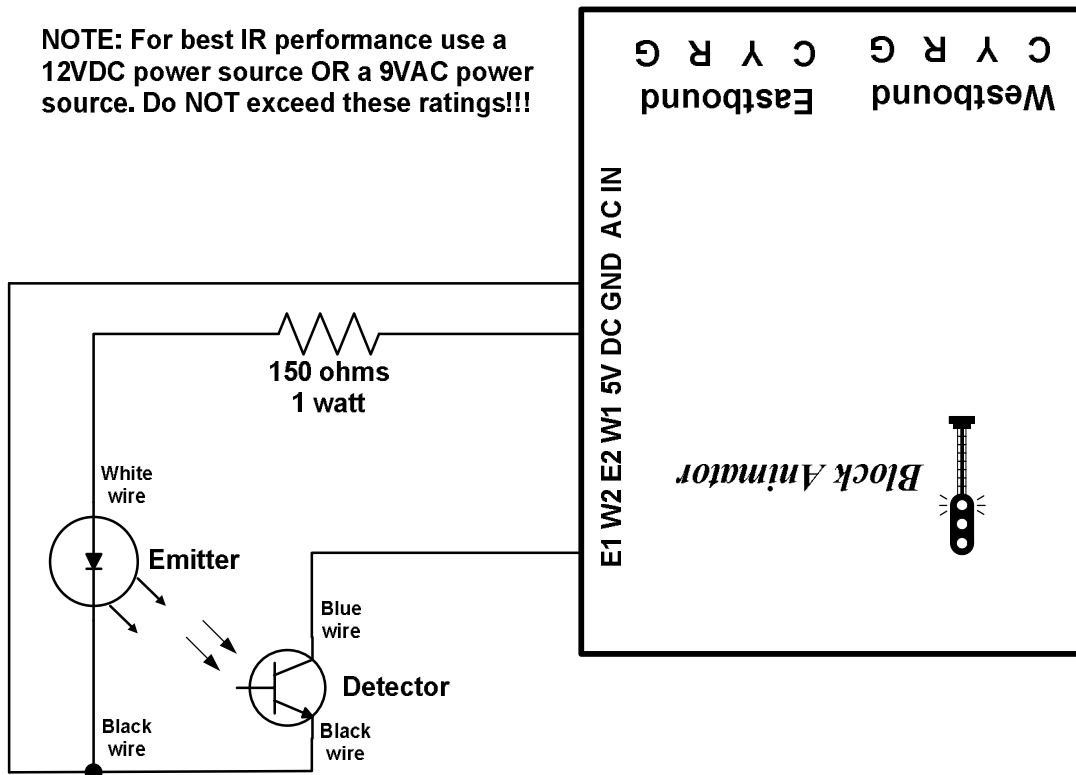

Figure 8 – IR component wiring

Sensor sensitivity setup

You can adjust the sensitivity of each IR detector on the circuit board using a small slotted head screwdriver. Along one each of the board are four potentiometers (or “pots”) that are labeled “W1”, “E2”, “W2” or “E1”. The **BA** supports a SETUP mode to make this adjustment process easier. To enable this mode, you must have the switch labeled SETUP in the ON/CLOSED position. In this mode the signals will not change colors. The **BA** circuit board contains a red LED near the configuration switches; this LED will assist you in setting the sensor sensitivity. Now follow these steps:

1. Remove all obstacles that may be covering the sensors.
2. Turn all four adjustment pots fully counter-clockwise and verify that the red LED is off.
3. Place a piece of rolling stock over sensor W1. Insert the blade of the screwdriver (from the edge of the circuit board, not from the center of the board) into the W1 adjustment pot. Turn the screwdriver completely counter-clockwise (left).
4. Slowly turn the adjustment pot clockwise until the red LED turns on.
5. Continue turning the adjustment pot slightly more clockwise. Move the rolling stock away from sensor W1 and verify that the red LED turns off.
6. Repeat steps 3-5 for the three remaining pots.
7. Exit SETUP mode by putting the SETUP switch in the OFF/OPEN position. The signals should now operate properly. You may wish to repeat this procedure with any other layout lighting conditions you operate under (e.g. “daytime” vs. “nighttime”).

Signal delay

The signal color delay (when the signal changes from yellow to green) can be either 10 seconds or 30 seconds. Choose the value based on your own personal preference. To select 10 seconds the configuration switch labeled DELAY must be ON/CLOSED; for 30 seconds the switch must be OFF/OPEN. You can change this as you wish even when the power to the **BA** is on.

Power

The **BA** accepts 7-9V AC or 9-12V DC power. Power consumption for LED signals is approximately 360mA (including the signals). If you are only using a single **BA** then use the TWO AC terminals to provide power (polarity doesn't matter). CAUTION: Most AC or DC accessory terminals on your throttle/power pack exceed 12V and cannot be used with the **BA**! However, you can use those power sources in conjunction with our 12VPSR which will provide 12V DC. If you are using more than one **BA** you can power them all from a single 9-12V DC source as shown in Figure 9 below.

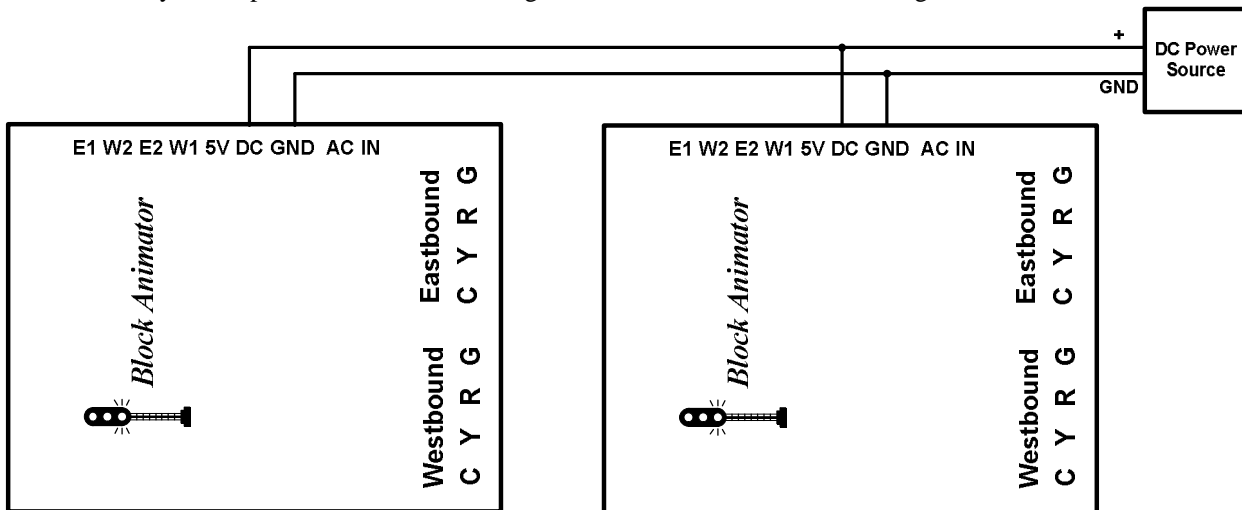

Figure 9 – DC power

Multiple signals

It is possible to use two signal heads with one **Block Animator**. This arrangement could be used to mimic a standard block signal arrangement. The signal heads will be wired in parallel with each other (each signal must have its own resistors) and obviously will always show the same indication.

Other Applications

Please contact us if you are interested in knowing how to interlock your signal (i.e. force it to red) with the position of a turnout or if you are interested in controlling a dual head signal with two **Block Animators**. We have an instruction supplement that covers these applications as well as illustrates use of the **Block Animator** with the signals arranged as opposite ends of a long section of track. You can also access this documentation online from our website at http://www.logicrailtech.com/lrt_docs.htm.

Troubleshooting

If you're using a searchlight signal and the signal is red when you think it should be green and vice versa then you probably just need to reverse the R and G connections.

If your signals do not change when a particular sensor is activated then you can perform the following tests. First, perform the sensor setup routine previously described. If one or more of the sensors does not function properly then you know it is faulty. If the sensors are OK then you might have a problem with the **BA**, the signals, or the wiring between them.

If the red LED on the **BA** board stays lit when the **BA** is in SETUP mode then there is a problem with: sensor sensitivity, sensor wiring, or one of the chips on the **BA**. First, double-check your sensor wiring. A missing sensor connection (missing wire or open circuit) will be interpreted by the **BA** as a cleared sensor. A shorted sensor (i.e. blue and black wires touching) will be interpreted by the **BA** as an activated sensor. Next, put the **BA** in SETUP mode (see page 1) and turn all four sensor sensitivity pots completely counter-clockwise (left). If the red LED goes out then simply complete the sensor setup process continuing with Step 3 on page 4. If the red LED is still lit then the problem is either a bad sensor or a faulty chip on the **BA**.

You can determine if the **BA** sensing chip is working correctly by TEMPORARILY disconnecting all blue sensor wires from the **BA**. If the red LED on the **BA** is lit then its sensing chip is faulty (read on below for details on replacing it). If, on the other hand, the red LED on the **BA** is now dark then connect each sensor input (E1, W2, E2, W1) to GND, ONE sensor input at a time. An activated sensor appears to the **BA** like a connection to GND so you are, in effect, mimicking an activated sensor with this test. If the red LED does NOT come on each time you make that temporary connection (make sure you try all four sensor inputs!) then you have a faulty chip.

The chip that "processes" the sensor inputs is located closest to the photocell sensitivity pots. This chip is labeled "LM339". Replacements are available from us or you can purchase one from stores such as Radio Shack (part number 276-1712). To replace the chip you will need to gently pry it out of its socket using a flat blade screwdriver. Take great care when inserting the replacement chip so that you don't bend any of its pins underneath it. Make sure the text on the chip has the OPPOSITE orientation as the name "Block Animator" on the circuit board.

Warranty

This product is warranted to be free from defects in materials or workmanship for a period of one year from the date of purchase. **Logic Rail Technologies** reserves the right to repair or replace a defective product. The product must be returned to **Logic Rail Technologies** in satisfactory condition. This warranty covers all defects incurred during normal use of this product. This warranty is void under the following conditions:

- 1) If damage to the product results from mishandling or abuse.
- 2) If the product has been altered in any way (e.g. soldering).
- 3) If the current or voltage limitations of the product have been exceeded.

Requests for warranty service must include a dated proof of purchase, a written description of the problem, and return shipping and handling (\$6.00 inside U.S./\$10.00 outside U.S. - U.S. funds only). Except as written above, no other warranty or guarantee, either expressed or implied by any other person, firm or corporation, applies to this product.

Technical Support

We hope the preceding instructions are sufficient for answering any questions you might have about the installation of this product. However, technical support is available should you need it. We would ask that you first contact your place of purchase for assistance. If you still need further assistance then please do not hesitate to contact us. You can reach us via phone, mail and email; our contact information can be found on the top of page 1.