

The PSX-AR Series (Rev:H)*

Intelligent, DCC, Solid State Circuit Breaker and Auto Reverser
Integrated Control for Stall Motor Switch Machines for Loop Automation
Integrated (Current and Photo Cell) Block detection
Quick Start: see Pg-9 All Programming is Optional!

★ Designed by Larry Maier ★ Developed by DCC Specialties ★ Patent Pending

The Power Shield X series is a product of years of research into problems dealing with false overload that cause premature shut down of DCC Boosters and other Circuit Breakers. These false overloads are caused by large capacitors used in sound systems decoders or lighted passenger cars. The overload appears as a short circuit until the capacitors are charged. The logic on the new Power Shield X Series determines if the load is a true short or just an overload due to discharged capacitor. The PSX-AR also has the logic and power to control switch machine(s) at the throat(s) of a reversing loop(s). Many other new features are also included.

There are (4) versions of the new PSX-AR Series:
Integrated DCC Circuit Breaker and Auto-Reversers

- (1) PSX-AR, w/ integrated Stall Motor Decoder
- (2) PSX-ARFB, same as above has added network FeedBack
- (3) PSX-ARSC, w/ integrated Snap Coil Decoder
- (4) PSX-ARSCFB, same as above has added network FeedBack.

The PSX series also includes 4, DCC Power District Circuit Breaker that incorporate all the same intelligent and exclusive features:

- PSX-1: 1 Block Control PSX-3: 3 Block Control
PSX-2: 2 Block Control PSX-4: 4 Block Control

PSX-AR List \$59.95 and PSX-ARSC List \$69.95

**Instructions by Don Fiehmman*

All Solid State Operation: Fast, all solid state design with reliable quiet action.....no clicks or sparks.

Automatic Coordination of Auto Reverse and Circuit Breaker Tasks: It is both a auto reverser and a circuit breaker.

Automates Reverse Loop Turnouts: Integrated Stall Motor or Snap Coil Decoder, automatically lines up switch machines when the polarity is reversed. Switch machine can also be controlled with standard DCC Accessory Commands or push buttons.

Adaptive Load Reset: Electronically determines if the overload is a real short or due to excess capacitance in sound decoders or lighted passenger cars.

Boost for Low Power Systems: Some low power DCC Systems boosters need a boost when resetting. Adding this jumper helps reset low power output systems.

Block Detection: Either a photo cell or current can be used to detect a train in a block. The photocell can turn off the block. A DCC command can then restore the power.

Auto Stop with CV Reset: A photocell can detect a train in the reverse section and turn off power. A DCC command can then restore the power.

Over Voltage Protection: If there is over voltage on the track caused by a DCC System failure or other power inputs the PSX will shut down and protect decoders

Wide Range of Current Trip Setting: The currents can be adjusted over a range of 1.27 to 17.8 amps. Values can be set either with CV settings or Jumpers.

Very Low Voltage Drop: Breaker On resistance is less than 0.060 ohms, so the PSX has a low voltage drop even at high currents. Much better than detectors that use a diode voltage drop.

Manual or Automatic Reset: Automatic reset of the breaker or use a switch for a manual reset.

Power On/Off by DCC: Turn on/off output track power with your DCC Throttle!

Outputs for LED Indicators: LEDs can be added to monitor the input/output power and the status.

System Reset: CV63=42 sets all CVs to original factory values.

Output for Audio Alert: An audible sounder can be added to the card to alert if there is a short.

No Power Supply Needed: Board size: is 5 3/4 by 3 3/4 inches, designed to fit standard Radio Shack Enclosure.

Flash Programmable: Micro Processor can accept updated software if needed.

PSX-ARFB, List \$64.95 and PSX-ARSCFB, List \$74.95: all of the above plus Feed Back and Block Occupancy Feed Back, Digitrax (LocoNet), Lenz (ExprssNet) and NCE (CabBus) for Occupancy and Shorted Status Block Occupancy Outputs: Indicates block occupied or if there is a real short, Occupancy Amps adjustable

Why Divide my Layout? (Courtesy of Kalmbach Publications)

Though DCC offers a more realistic type of train control – being able to run multiple locomotives independently on the same track – the electricity running through the rails of your layout still needs to be properly managed and distributed. Since one of the big selling points of DCC is that you don't need to divide your layout into individual electrical blocks for independent train control, you're probably asking yourself, "why should I do it?" In addition to minimizing operating disruptions, power districts are also a key to DCC power regulation. If you're running a lot of trains, you'll need to make sure your DCC system can supply all your power needs efficiently and safely. Adding power districts to your layout can help with that. By separating your layout into districts, you divide the total track power available into smaller, more manageable units.

How do I Determine Districts?

There are really two types of power districts: those that are circuit-breaker protected zones on the layout and those that have their own independent Booster (also breaker protected). Probably the best way to determine where to place power districts is to take a look at the expected current draw, (Traffic), for each operating location on the layout. For example, a busy yard might have two switchers, one or more trains on the arrival and departure tracks, another train or two passing the yard on the main, and maybe a peddler working nearby local industries. If some or all of these trains have more than one locomotive, you could have 10 to 15 current-drawing units all competing for power in a fairly small area. Even assuming that the locomotives have efficient motors, this type of load may be heavy enough to slow down a DCC system running on a common 5A booster. Generally, our experience has shown that in HO if you have for a 12-14 awg buss and 20 awg feeders, that a 5 Amp system can support up to 10 Operators. Many users overestimate the amount of Booster power needed. Try using the PSX Series first, then if your trains start to slow down you may need to add extra Booster to support the concentration of trains in this location. By dividing a layout into power districts in this manner, and using a combination of boosters and circuit breakers, you can make the most efficient use of available power on any mid-size or large-size layout.

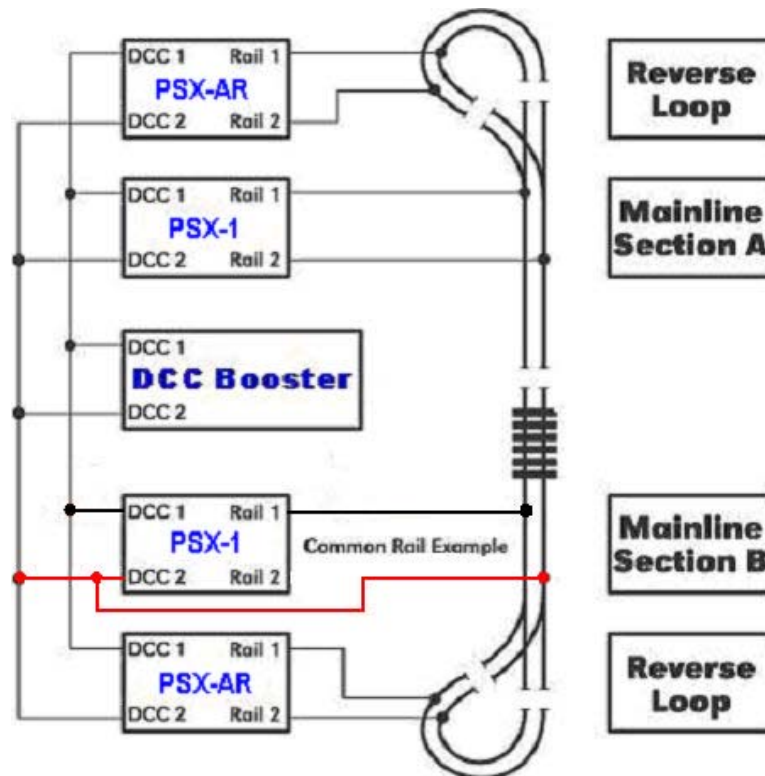

Connections and Wiring:

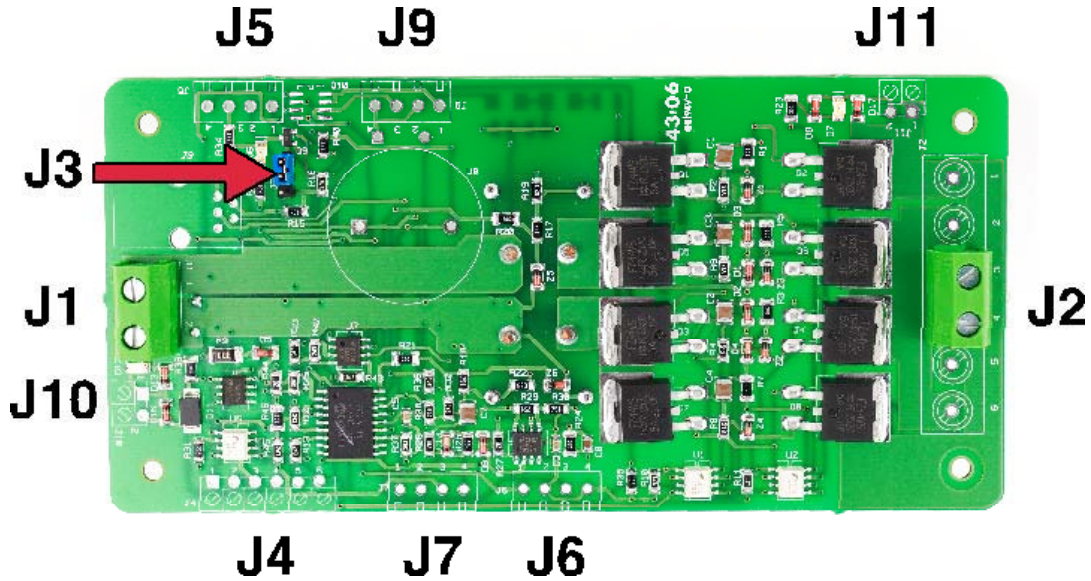

Note:

Newer versions of the PSX-AR will have the sensing transformers mounted on the topside of the circuit bd.

J1 Input Power Connector		J6 Trip Current Settings	
J1-1	DCC Input 1	J6-1	See Text for Jumper
J1-2	DCC Input 2	J6-2	Settings and Current
		J6-3	Outputs
		J6-4	
J2 Output Power Connector		J7 Auto/Manual Reset- Inrush Boost	
J2-1	DCC Output 1	J7-1	1-2 Open for Auto Reset
J2-2	DCC Output 2	J7-2	1-2 Closed for Manual Reset
		J7-3	Connect 3 to 4 to
		J7-4	Enable Inrush Boost
J3 Program Jumper		J8 Factory Only Connection	
J3-1	Connection 1-2 for Programming		
J3-2			
J3-3	Connection 2-3 for Operations	J9 Dual Coil Switch Mach Option	
		J9-1 (-)	Switch Coil Output
J4 Block Occupancy		J9-2 (+)	Switch Common
J4-1	Photo Cell connections pin 1 and 2	J9-3 (-)	Switch Coil Output
J4-2		J9-4 (+)	Switch Common
J4-3 (+)	Block Occupied output pin 3, 4	J10 Input Power (On) Led (Remote)	
J4-4 (-)	J4-3 -4 Network Feedback	J10-1 (+)	
J4-5 (+)	Short Circuit detected output (5mA)	J10-2 (-)	
J4-6 (-)	J4-5,-6 Network Feedback	J11 Track Power Led (Remote)	
J5 Switch Outputs		J11-1 (+)	
J5-1	To Tortoise Pin 1 (see text)	J11-2 (-)	
J5-2	To Tortoise Pin 8		
J5-3 (+)	Remote Status LED (anode)		
J5-4 (-)	Remote Status LED (cathode)		

Connections and Wiring:

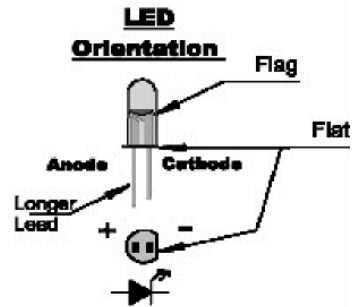
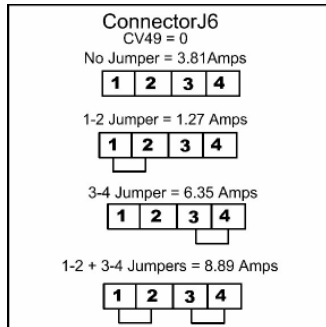

This chart shows the jumper setting for a few of the available current trip points. The current values can also be set with values in CV49. Note CV49 must be set to "0" for J6 jumpers to work. See pg-5 and 7 for more info and all the settings.

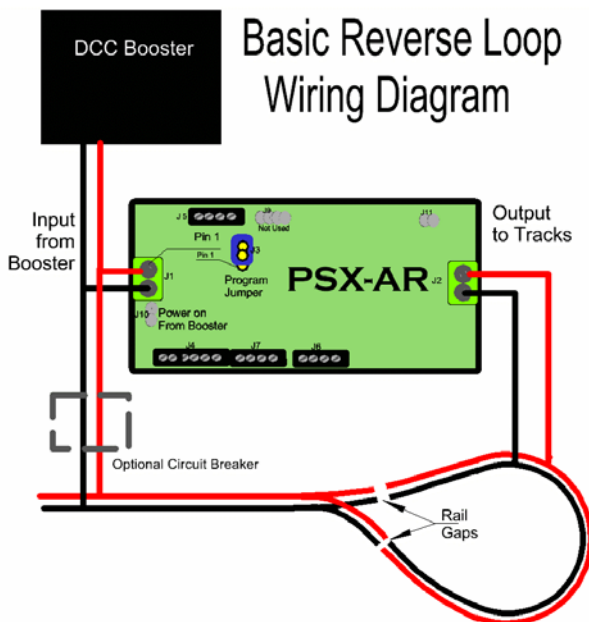

The drawing to the left is the basic wiring for a reversing loop. It can also be used for wyes and turntables. Wire size to the input of PSX-AR should be heavy enough to carry the current, 12-18 AWG. The size of wire depends on your scale and the load, # of loco's operating! Too much resistance can result in faulty short sensing. The length of the reversing section of track between the gaps should generally be longer than the longest train that will use the section of track. See **User Guidelines** for exceptions, pg-8.

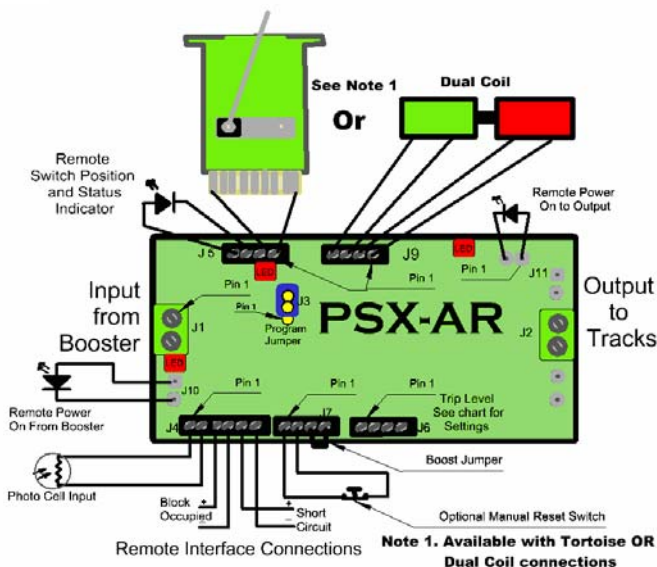

The drawing below shows all the possible connections to the PSX-AR Series

Note, the PSX-AR comes set up for a stall motor stationary decoder. The PSX-ARSC comes set up for a "Snap Coil" stationary decoder. The PSX-AR and the PSX-ARSC are not interchangeable.

Note: The small black screw terminals shown in picture are optional accessories available from your dealer. The large green input/output terminals come with units. Generally the small terminals are not needed as most of these are on-time connections and are easily soldered to the bd. Use a small iron (20W-40W) for soldering to the bd.

Connections and Wiring:

J1 – DCC power input connections from the booster. See also the diagram on previous page.

J2 – Reverser output to the reversing track. Use the screw terminals connected to J2, 3-4. It has parallel outputs for multiple loop connections if needed, J2, 1-2 and 5-6.

J3 –Programming jumper. J3-2 to J3-3 is the operating configuration. J3-1 to J3-2 when connected at power on sets the reverser to enter the programming mode.

J4-1 and **J4-2** are the inputs for the photocell detector used for the stopping function. Note: Be sure there is sufficient light above the cell to trigger the circuit. The photocell sensitivity is automatically calibrated each time it is armed. Silonex NSL-6112

J4-3 (+) and **J4-4**(-) are open if the block is not occupied and are connected together (up to 5 ma) if the block is occupied. This is an opto-isolated output switch and provides no power.

J4-5 (+) and **J4-6** (-) are connected together (up to 5 mA) when the reverser has detected a short circuit and open with no short .This is an opto-isolated output switch and provides no power.

J5-1 and **J5-2** are connected to pins 1 and 8 of a Tortoise switch machine. The reverser will align the Tortoise with the direction of the reverser. Pin 1 and 8 on the Tortoise may need to be swapped to make sure the switch point direction aligns with the polarity of the reverser. A bi-color LED can be used in series with the Tortoise to indicate the switch position

J5-3 (-) and **J5-4** (+) are for a remote status LEDs. The LED is connected directly to the terminals. No resistor is required. (**Off** means **normal**) – (**blinking** means **reversed**) – (**steady on** means a **short circuit**.)

J6 – Sets the current trip level when CV49=0. CV49 default is 03 which will set a trip current of 3.81 amperes if no jumpers are installed. If J6-2 is connected to J6-1 and J6-4 to J6-3 is open, then the current trip is 1.27 amperes. If J6-4 is connected to J6-3 and J6-2 to J6-1 is open, then the current trip is 6.35 amperes. If J6-4 is connected to J6-3 and J6-2 is connected to J6-1, then the current trip is 8.89 amp. See pg-6 for all settings.

J7-1 and **J7-2** are the auto/manual reset input. If the connections are open, the breaker will automatically try to reset. If the terminals are connected together (like a SPST toggle switch or a N/C push button switch), then the breaker will remain off after a short until the connection from J7-1 to J7-2 is momentarily off

J7-4 to **J7-3** Is the **Inrush** booster enable jumper. When the jumper is installed, the breaker will use a turn on algorithm that is designed to assist low power or overly sensitive boosters in starting high inrush current loads. It will also assist low power boosters such as the Zephyr and the NCE Power Cab to re-start difficult loads. When CV53 is zero, the jumper will enable/disable this function. If CV53 is a non-zero value, then the boost function is enabled regardless of the presence or absence of a jumper.

J8 is the software upgrade interface and not for consumer use.

J9 is the dual coil switch machine output when the PSX-ARSC hardware is configured for dual coil operation. J9-2 and J9-4 are the positive output voltage. One coil is connected to J9-1 while the remaining coil is connected to J9-3. Which coil to which terminal is determined by which way the points are aligned when the PSX-ARSC is in its normal state.

J10-1 (+) and **J10-2** (-) are for a remote indicator showing input power is coming into to the PSX-AR

J11-1 (+) and **J11-2** (-) are for a remote indicator showing that the track outputs are on (or off).

Timing Settings:

Note: there are no jumpers or CVs for setting time delays. The unit uses its own timing algorithm to figure out how to turn **on** under a load. It differentiates between a short and a surge load, and operates accordingly. It will also recognize a difficult starting load and try to help the booster get it operating without tripping the booster's internal shutdown.

Setting Addresses and Programming CV's: Optional/Not Required!

Programming Steps:

The easiest way to program the Power Shield X is on-the-bench with or without the switch machine. Connect pins J 1-1 and J 1-2 to the output of your DCC system. There is a small red LED on the Power Shield that will blink each time a command is accepted. There is also an LED near the power input and one near the power output used to indicate power status. If you plug in a spare switch machine the command can be tested when finished programming and have returned the program jumper back to the RUN position. If you make a mistake, don't worry, just go back and program the CV to the desired value. If you are hopelessly lost, set CV63 to 42 and you can start over again with factory default values.

(1) **Do Not Use Program Track!**

(2) **The PSX-AR's addresses are SET by moving the program jumper as described below and issuing Accessory Commands.....like operating by using your DCC Throttle, pg-10**

The Table to the right shows how the DCC Manufactures identify the **Normal (Clear)** and/or the **Thrown** Route to operate accessories.

System	Normal(Clear)	Thrown
Digitrax	C or Closed	t or Thrown
Lenz	+	-
MRC	ON	OFF
NCE	Normal/ON/ 1	Reverse/OFF/

(3) **Configuration CV's are Programmed in Ops Mode, "on the main", also by moving the programming jumper, see Pg 10. Use any non-loco address, except defaults, to initiate Ops Mode.**

(4) **It is important to remember that Addresses are Set and CV's are Programmed!**

Special Programming Instructions:

Specific DCC Systems need to follow specific programming sequences to reliably program the **PSX-AR's**, see pg-10

NCE and MRC: Do not use the Accessory Programming Mode, only use Ops Mode for CV's see pg-10

Digitrax: see pg-10

Digitrax users should review the settings of the Digitrax, DCS-100/200 prior to programming a PSX-AR. It is important that the DCS-100/200 has the Switching (Accessory) Control enabled otherwise it will not operate Stationary Decoders or Accessories. The Digitrax Command Station sends out up to eight accessory addresses every time you use your throttle to turn track power on and/or you reboot the system and have track power set for auto turn on. If you connect the PSX-AR to the Digitrax system with the PSX-AR's *jumpers* set to the programming mode, these eight addresses will be programmed. It is recommended for Digitrax that the Setting of Addresses and Programming of CV's be done at the same time to avoid the accidental Setting of Addresses as described above. See Pg-12.

One Solution:

Turn on the command station and wait a minute before connecting the **PSX-AR's** so that it will not see these addresses.

Better solution:

Follow the directions above for setting the **PSX-AR's** to the programming mode by moving the jumper and then turn on the Digitrax system. The eight addresses will be stored. Select and use OPS mode programming to set CV63 to 0, which resets to default settings, and the **PSX-AR's** is ready to program normally. This does mean that you want to be careful if you have already programmed some addresses. These can be over-written by the Digitrax system. Your best bet is to keep a list of the address set in each, when you want to add addresses, you will have to set CV63 to 0 and then re-program the original addresses before adding the new ones.

Lenz: See also Pg-10.

The Lenz system sends repeat accessory commands as long as you hold down the 1 or 4 command key. This ensures that the accessory decoder sees the message, but can result in the same address stored multiple times while programming the **PSX-AR's**. The solution is simple. Hold the 1 or 4 key down for only a short time. Once you see D10 flash indicating an address has been stored, release the control key. If you see multiple flashes, you have stored the same address more than once. Since the **PSX-AR's** will flash D10 each time you send it an accessory address, you can easily get a feel for the timing involved. In the normal operating mode (not programming mode), select an accessory address that has not been programmed into the **PSX-AR's**, send an accessory command to this address and hold down the 1 or 4 control key. D10 will flash each time the command station repeats the accessory address. This will give you a feel of how long to hold the control key while you are programming multiple address.

Setting Addresses and Programming CV's: Optional/Not Required!

There are **Three** (3) Accessory Addresses:

(1) The **First** accessory address lets you turn the output track power from the Power Shield on and off. (Default address 2042)

(2) The **Second** address is used to arm the photocell circuit. When the light level drops, due to a train covering the photo cell, the power will turn off. Power can be turned back on (or off) under DCC control. The second address (2043 default) arms (when the command is "on") the photo detector to turn the output **off** when the light level drops. This is designed to allow you to stop a train on a hidden staging track by arming the photo detector and then the reverser will turn off power to the section when the train covers the photo detector. Once the photo detector has tripped, it will not turn **off** track power until it is armed again with this accessory address command.

(3) The **Third** address (2044 default) controls the output to the stall motor or dual coil switch machine outputs by using a normal DCC accessory commands for a switch, throw(off) or clear(on) command.

Setting the Three Accessory Addresses:

Addresses are set by moving jumper, J3 to positions 1-2 for the program mode with power **off**. Turn power **on**, See **Digitrax Caution** and the **next** accessory command issued by the DCC system will be stored as the **first address**, (track power on/off). By default, the unit will store the **next two** consecutive addresses for the second and third address. Once the address is entered you can use either the on (clear or +) or the off (throw or -) function. If no further addresses are sent by the DCC system, you will have **three sequential addresses** starting at the address you sent in the program mode. If you **continue sending addresses** to accessories, then these will be stored as the **second and third addresses**. Thus, you can have three sequential addresses starting at any desired address, or you can have three random addresses. Remember to power **off** and put the program jumper back to 2-3, unless you are going to program CV settings. Note: When changing from **run** to **program** mode, wait about 1 minute before turning power back on to the PSX-AR.

Reference Chart for the Three Accessory Commands

Function	Default Address	Your New Address
Arm Output for Photo Cell	2043	?
Turnout Accessory Address	2044	?
Track Power On/Off	2042	?

Programming the CV Values:

Programming the CV values is done using the Programming-on-the-Main (POM) function. With power **off**, put the programming jumper on pins 1-2, then turn power back **on**. Then go into the Program-on-the-main mode. You will need to setup a "fake" loco address in order to get to the CV setting operation. Put in any address. (**Not** an address that is in use on the layout.) Hit enter, then you can start entering the CV numbers followed by the values. When done, turn power off and replace the program jumper to pins 2-3.

CV49 – sets the current trip value. If CV49=0, then the Trip Current jumpers on J6 are enabled. Remember to use either the Jumpers or the CV settings, not both! . . . The following trip currents can be set by programming:

Caution continuous operations at a value higher than CV49=08, (10.2 amps) without the addition of heat sinks to the output transistors may overheat or damage the PSX-AR!

Trip Current Jumpers

CV49 Value	Trip Current (Amps)	Continued	
		CV Value	Trip Current
00	3.81 See Chart to Right	08	10.2
01	1.27	09	11.4
02	2.54	10	12.7
03	3.81 (default value)	11	14.0
04	5.08	12	15.2
05	6.35	13	16.5
06	7.62	14	17.8
07	8.89	15	19.1

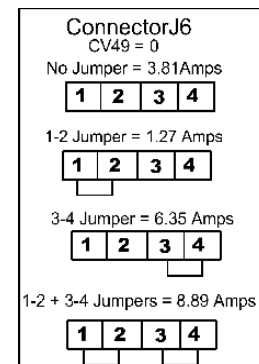

Setting Addresses and Programming CV's: Optional/Not Required!

CV49 Continued. For the Digitrax Zephyr, 01 or 02 (maybe) are OK. The NCE Power Cab should use a value of 01. Both systems benefit by the activation of the Inrush boost mode. Most 5 amp boosters should be happy with 03 or 04.

CV50 is the block detection source selection. CV50=0 selects block current as the parameter to activate the Block Occupied (J4-3 and J4-4) output. CV50=1 will use the photo cell to activate the Block Occupied output when the photo cell is covered. Note that the photo cell is self-calibrating and will adjust itself to the ambient light level at the time that the unit is turned on. If you need extra photo cells, they are made by **Silonex** part number NSL-6112, available from Miniaturics, and Allied Radio. The CV50 default is 0.

CV51 is not for use by the consumer.

CV52 sets the power on position of the reverser and the Tortoise (or dual coil) switch output. CV52=0 turns on in the "normal" position. CV52=1 turns on in the "reverse" position. Note that the switch position is locked to the status (reverse or normal) of the reverser. The CV52 default is 0.

CV53 enables or disables the Inrush boost. CV53=0 disables the boost unless the boost jumper is installed. Any other value enables the boost regardless of the presence or absence of a jumper on J7-3 and J7- 4. The CV53 default is 0.

CV54–CV62 are not used at present.

CV63 allows control of the address programming point (same as on the Hare). **Setting a value of 42 to CV63 will cause the reverser to set all CVs and addresses to factory defaults.** The CV63 default is 0.

CV64 sets the block current trip level for activating the Block Occupied output (J4-3 and J4-4). When CV64=0, the trip current is about 5 mA. CV64=0 is the default value. Increasing the value of CV64 will increase the value of the trip current. This will allow setting the trip current in a block in which the unoccupied current is greater than 0. CV64 is set, (with the block unoccupied), by increasing the value in CV64 until the Block Occupied Output just de-activates.

After Programming the CVs turn power off and put the program jumper back to run position, J3, 2-3.

Manual Turnout Control:

If you need to return the turnout to the reset position with out issuing a DCC command, here is a simple solution. Install a normally closed pushbutton switch in series with one of the power leads to the input to connector J1. When you need to reset the turnout, operate the pushbutton for a moment and when you release the PowerShieldX-AR will go through a power on reset and the switch will return to the normal position

Mounting the PSX-AR:

The PSX-AR Series can be mounted using a 1.25" #4 wood screws and a 3/4" spacer. The spacer can be either metal or plastic. Also, the PSX-AR series was designed to fit into the box, pg-8. Radio Shack #270-1805.

See also Accessories below, pg-8

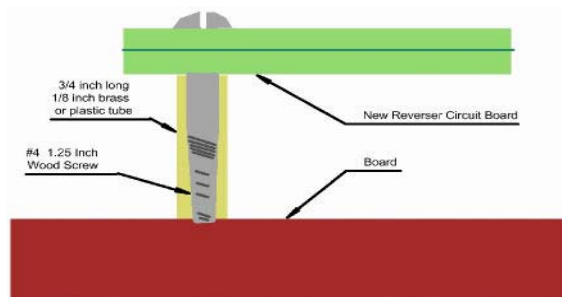

User Guidelines:

Power Shields are designed so all input/output connections are made to the screw terminals. Use up to 12 AWG wire. If you are using heavier buss wire, then solder a short length of 12 AWG wire to your heavier buss. If your Power Sections and Reverse blocks are greater than 10 Ft. long be sure to have at least 2 sets of track feeders for that section. Insufficient feeders will cause a voltage drop.

When setting up gaps for reverse sections, we recommended that the gaps be staggered about 1/8 ". Perfectly aligned gaps may reduce the current needed for **PSX-AR** to reverse properly.

If your train is longer than your reverse block and has metal wheels, you may need to cut additional gaps into the reverse section. Simply cut another set of gaps at both ends of the reverse sections inside of the original gaps. The distance between these gaps and the original gaps should be longer than the wheelbase of any metal truck.

Note that one end of the reverse section will be aligned with normal polarity track power

while the opposite or other end will have a polarity mis-match and require the reverser to act.

Test your **PSX-AR** installation prior to running a train as follows.

Observe that your DCC booster is not shorted.

Use a suitable metal object to separately short each of the four gaps that form the reverse section and observe the LED on the **PSX-AR**

Shorting the two rail gaps where the polarity is aligned will produce NO LED Indication from the **PSX-AR**

Shorting either rail gap where the polarity is mis-matched will cause the LED to rapidly flash. You can also short both rails in the reverse section and the LED will stay on until the short is removed.

If you are using both Power Shield X Breakers and Reversers on a layout, and the locomotives hesitate when crossing a reverse gap, then increase the Trip Current on the Power Shield Breakers to the next level or until the PSX-AR operates correctly

Accessories:

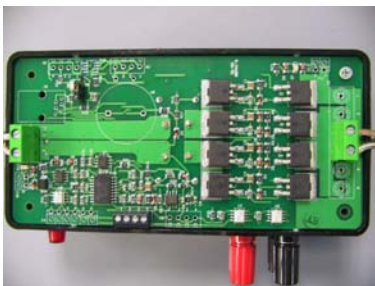

(1)

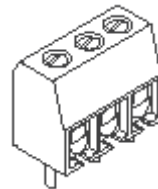

(2)



(3)

(1) The PSX-AR was designed to fit into the box above, Radio Shack #270-1805, also try your dealer.

(2) The Screw Terminals are available from your dealer.

(3) The Alarm is Digikey, 458-1005, also try your dealer.

(4) Two heat sinks, not shown, Digikey 294-1085, may be needed, for each group of (4) output Transistors. Also, we recommend Digikey, BER158, double-sided thermal tape (10" x 10" sheet, cut into strips) to attach the heat sinks to the (8) large black output transistors.

Feedback:

Interfacing to Digitrax Loco Net, NCE Cab Bus and Lenz XpressNet

The **PSX-AR** has optional outputs that allow you to convey the occupancy and the short circuit status to your; NCE Cab Bus, your Lenz XpressNet, or your Digitrax Loconet. These connections are made using hardware available from the respective system manufacturers. The diagrams below show you these connections. Follow your manufacturers directions for use of the data.

Status Indication For Digitrax DS54 & DS64

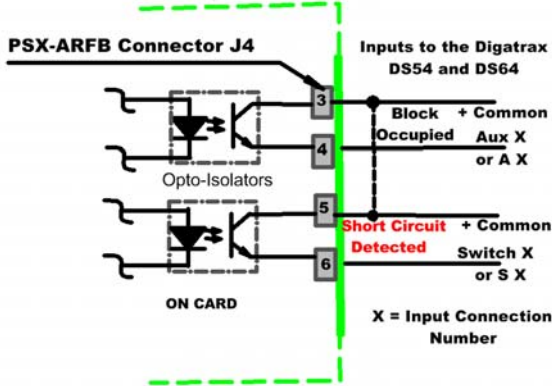

Status Indication For Lenz LR101

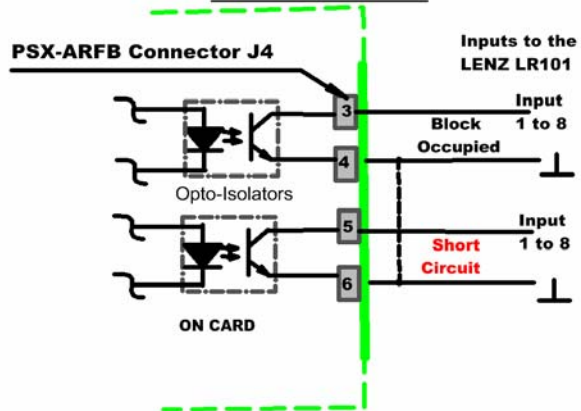

Status Indication For NCE AIU

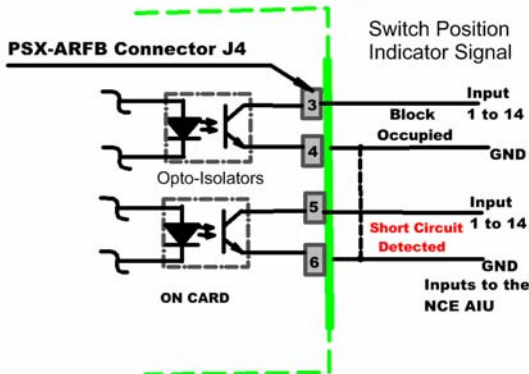

Quick Start

(A) All connections involve (2) Inputs from the DCC Booster or the main line buss and (2) Outputs to the isolated reverse block!

(B) PSX-AR is ready to operate without using programmable options!

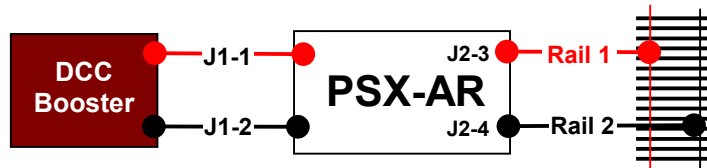

Before wiring, check that the program jumper is on pins 2-3 of J3. (Pin 1 is nearest the center of the card.) See the drawing on this page.

1. Be sure to connect the two wires from the booster to the INPUT and the two wires to the reversing section or loop to the OUTPUT connections. **If you connect DCC Buss Power to the PSX-AR outputs you will damage the PSX-AR!**

2. When power is applied the **red LED's, D12** near the input and **D7** near the output should be **on**. If the status LED, **D6** near the program jumper is **on** solid, you may have a short between the two wires from the output or in the track section. If the status LED, **D6** is blinking then polarity has reversed.

3. If you short the output **quickly**, simulating a short caused by wheels crossing the polarity gap, the status LED should start to blink. A long short will cause the status LED to come on steady.

4. If the long short shuts down the booster instead of the circuit breaker in the PSX-AR, you may have to set the circuit breaker to a lower trip current. Either jumpers or a CV setting can be changed. See CV49, pg-6. See User Guidelines pg-8

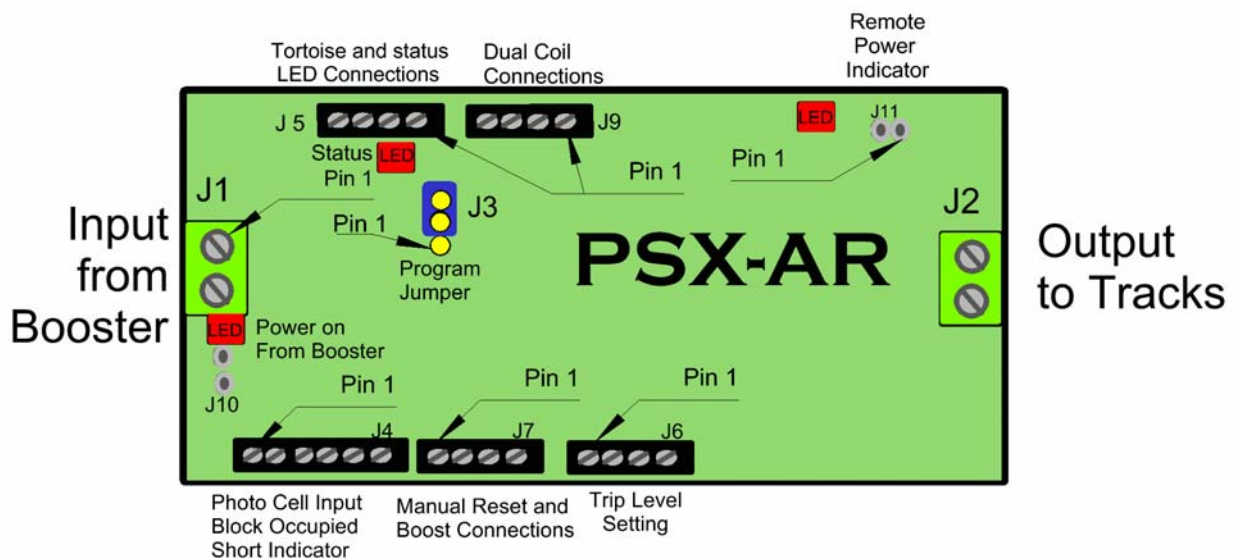

Note: The small black screw terminals shown in picture are optional accessories available from your dealer. The large green input/output terminals come with units. Generally the small terminals are not needed as most of these are one time connections and are easily soldered to the bd. Use a small iron (20W-40W) for soldering to the bd.

Sequential Programming Instruction for **Setting the Address** and **Programming CV's**

Digitrax PSX-AR: Using the DT-400

Setting PSX-AR Addresses:

1. Disconnect PSX-AR from DCC power
2. Move PSX-AR Jumper to Program Position
3. Turn DCC power on "PWR"+ "Y+"
4. After 30 seconds, reconnect DCC power Program CV's at this time (see below)
First, In CV 63, enter a value of 42 to reset. Then set any other CV's needed. Do not Move Programming jumper or turn off power. .Exit program mode and go to step 5.
5. Press "SWCH" key to enter Switch Mode
6. Select the switch number to be set using the keypad or RH knob.
7. Press either the "OPTN" or "CLOC" key to set address.
8. Repeat steps 6 and 7 until all addresses set.
9. Press "EXIT" key to return to LOCO mode.
10. Turn DCC power off "PWR" "N -".
11. Move PSX-AR Jumper to Run Position
12. Turn track power on. Test the switch address setting by using the "SWCH" key and switch addresses.
13. Turn power off and put the program jumper into the Run position.
14. Turn DCC power on. Test the PSX-AR using the switch commands.

Programming PSX-AR CVs

:Do Setting Addresses First, See Above

1. Disconnect PSX-AR from DCC power.
2. Move PSX-AR Jumper to Program Position
3. Turn DCC power on "PWR" "Y+"
4. After a few seconds, connect DCC power to the PSX-AR
5. Select an unused locomotive number with the keypad or RH knob.
6. Press "PROG" key until you get from Pg to Po
7. Use LH throttle to set, dial the CV number and the RH throttle for the CV value.
8. Press, "ENTER"
9. Repeat steps 7 & 8 until all the CV values are set.
10. Press "EXIT"

Lenz: Using the LH100:

Setting PSX-AR Addresses:

1. Turn DCC power off.
2. Move PSX-AR Jumper to Program Position
3. Turn DCC power on
4. Press "F5" key to select "SW" mode.
5. Enter the switch number to be set using the keypad, then press ENTER.
6. Press either the "+" or "-" key to set the address. Let LED blink once.
7. To enter another address press the "CI" key.
8. Repeat steps 5-7 until all addresses are set.
9. Press "ESC" key to return to normal.
10. Turn DCC power off.
11. Move PSX-AR Jumper to Run Position
12. Turn track power on.
13. Test the switch address setting using "SW" mode and the new switch address(es).

Programming PSX-AR CVs:

1. Turn DCC power off.
2. Move PSX-AR Jumper to Program Position
3. Turn DCC power on.
4. Select a locomotive number with the keypad that is unused on your layout.
5. Press the "F" keys and the "+" or "-" key to select "POM" mode then hit "Enter".
6. Press "+" or "-" until "CV" is displayed then press "Enter".
7. Key in the desired CV number then press "Enter"
8. Enter the CV value to change, then press "Enter".
9. The display will show the CV number and value to be programmed.
10. Hit "Enter" to program the CV, note the LED on the PSX-AR flashes when the key is released
11. Press "Esc" key to return to Step 7) or press "Esc" three times to exit CV programming
12. Turn power off and put the Program jumper into the Run position.
13. Turn DCC power on. Test the PSX-AR using the switch commands.

NCE: Using the Pro Cab or Power Cab

Setting PSX-AR Addresses:

1. Turn DCC Power off.
 2. Move PSX-AR Jumper to Program Position.
 3. Turn DCC Power on.
 4. Press SELECT ACCY.
 5. Then use the keypad to enter the new switch number.
 6. Press ENTER then press either 1 or 2 to set the address.
 7. Repeat steps 4 thru 6 until all of the switch addresses are set.
 8. Turn DCC Power off.
 9. Move PSX-AR Jumper to Run Position.
 10. Turn DCC Power on.
- Test the switch setting using the SELECT ACCY key.

Programming PSX-AR CVs:

1. Turn DCC Power off.
 2. Move PSX-AR Jumper to Program Position.
 3. Turn DCC Power on.
 4. Use SELECT LOCO to address an unused locomotive number.
 5. Press PROG/ESC key to enter PROGRAM ON MAIN mode.
 6. Key ENTER to select any unused locomotive number, then ENTER again.
 7. Key 2 to enter PROG CV NUM.
 8. Enter CV number then ENTER.
 9. Enter value to be stored then ENTER.
 10. Repeat steps 8 and 9 until finished.
 11. Press PROG/ESC to return to normal operation.
 12. Turn power off, put the PSX-AR Program Jumper into the Run position.
 13. Turn power on.
- Test the PSX-AR using the SELECT ACCY key.

MRC: Using the Prodigy Advance Cab:

Setting PSX-AR Addresses:

1. Turn DCC Power off.
 2. Move PSX-AR Jumper to Program Position.
 3. Turn DCC Power on.
 4. Press ACCY key.
 5. Then use the keypad to enter the new switch number.
 6. Press ENTER then press either 1 or 2 to set the address.
 7. Repeat steps 4 thru 6 until all of the CV value are set.
 8. Turn DCC Power off.
 9. Move PSX-AR Jumper to Run Position.
 10. Turn DCC Power on.
- Test the switch setting using the ACCY key.

Programming PSX-AR CVs:

1. Turn DCC Power off.
 2. Move PSX-AR Jumper to Program Position.
 3. Turn DCC Power on.
 4. Press LOCO to address an key in an unused locomotive number.
 5. Press PROG key to enter PROG MAIN TRACK mode, then press ENTER.
 6. Continue to press ENTER until CV# is in the display.
 7. Enter the CV number then ENTER.
 8. Enter the value to be stored in the CV then ENTER.
 9. Repeat steps 8 and 9 until finished.
 10. Press ENTER to return to normal operation.
 11. Turn power off and put the PSX-AR Program Jumper into the Run position.
 12. Turn DCC power on.
- Test the PSX-AR using the ACCY key.